

SCELBI COMPUTER CONSULTING, INC.

ASSEMBLY INSTRUCTIONS - SCELBI-8B P.C. CARD SET

INTRODUCTION

THE FOLLOWING INSTRUCTIONS APPLY TO THE ASSEMBLY OF ALL CARDS IN THE SCELBI-8B MINICOMPUTER KIT. THESE INSTRUCTIONS SHOULD BE READ BEFORE PROCEEDING TO THE INDIVIDUAL PARTS INSTALLATION INSTRUCTIONS WHICH FOLLOW THIS SECTION.

NOTES ON SOLDERING

USE A GOOD GRADE ROSIN-CORE SOLDER OF A TYPE INTENDED FOR USE WITH ELECTRONIC CIRCUITS. A SMALL 30 - 50 WATT SOLDERING IRON WITH A NARROW TIP SHOULD BE USED. DO NOT APPLY HEAT ANY LONGER THAN NECESSARY TO ALLOW THE SOLDER TO THOROUGHLY FLOW AROUND THE COMPONENT LEAD AND INTO THE HOLE SURROUNDING THE LEAD. THE CARDS SUPPLIED WITH THE SCELBI-8B HAVE PLATED-THROUGH HOLES WHICH MEANS THAT THE CIRCUIT FOIL EXTENDS DOWN THROUGH EACH HOLE WHERE AN ELECTRICAL CONNECTION IS MADE TO ENSURE THAT ALL CONTACTS ARE SOLID. FOR SUCH PLATED-THROUGH HOLES, THE PROPER AMOUNT OF SOLDER HAS BEEN APPLIED WHEN THE SOLDER HAS JUST STARTED TO CLIMB UP THE COMPONENT LEAD ON THE OTHER SIDE OF THE BOARD FROM WHICH SOLDER IS APPLIED. NORMALLY SOLDERING SHOULD BE DONE FROM THE SIDE OPPOSITE TO THAT ON WHICH THE COMPONENTS MOUNT. AFTER EACH CONNECTION HAS BEEN SOLDERED CHECK TO ENSURE THAT THERE ARE NOT ANY SOLDER SHORTS TO ADJACENT CIRCUITRY.

NOTES ON INSTALLATION OF INTEGRATED CIRCUITS

WHEN INSTALLING INTEGRATED CIRCUITS MAKE SURE THAT EACH I.C. IS PROPERLY POSITIONED. PIN #1 ON AN I.C. NORMALLY HAS A SMALL DOT (OR DEPRESSION) NEXT TO IT ON THE BODY OF THE CHIP. THE LOCATION OF THIS DOT WHEN THE I.C. IS INSTALLED SHOULD BE THE SAME AS THAT SHOWN ON THE ASSEMBLY DRAWING. IF A MARKER CANNOT BE FOUND ON AN I.C. THEN MAKE SURE THAT THE END OF THE INTEGRATED CIRCUIT WITH A DEPRESSION OR COLORED-IN AREA IS POSITIONED THE SAME AS INDICATED ON THE ASSEMBLY DRAWING. ALL INTEGRATED CIRCUITS ON THE SCELBI-8B PRINTED CIRCUIT CARDS MOUNT ON THE CARDS SO THAT THEY ARE ORIENTED IN THE SAME DIRECTION. WHEN INSTALLING AN I.C. MAKE SURE THAT ALL OF THE PINS ON THE PACKAGE GO THROUGH THE PROPER HOLES IN THE P.C. BOARD (IT MAY BE OCCASSIONALLY NECESSARY TO STRAIGHTEN A PIN ON AN I.C.) AND THAT THE BODY OF THE I.C. IS FLUSH TO THE BOARD SURFACE. ONCE THE INTEGRATED CIRCUIT HAS BEEN INSTALLED SEVERAL OF THE PINS PROTRUDING THROUGH THE BOARD SHOULD BE BENT AGAINST THE FOIL ON THE BACK SIDE OF THE CARD SO THAT THE COMPONENT WILL BE HELD IN POSITION PRIOR TO THE TIME IT IS SOLDERED. WHEN IT IS TIME TO SOLDER THE COMPONENTS TURN THE CARD OVER SO THAT THE COMPONENTS ARE FACING DOWN AND CAREFULLY SOLDER EACH I.C. PIN TO ITS FOIL PAD.

LOCATING POSITIONS OF DISCRETE COMPONENTS ON THE P.C. CARDS

SCELBI PRINTED CIRCUIT CARDS HAVE NUMEROUS HOLES IN THE BOARD MATERIAL THAT ARE LINED WITH A CONDUCTIVE MATERIAL AND THAT ARE SIMPLY USED

TO CONNECT CIRCUIT FOIL PATHS FROM ONE SIDE OF THE CARD TO THE OTHER SIDE. THESE HOLES ARE OFTEN TERMED "FEED-THROUGH" HOLES. IN ADDITION TO THE "FEED-THROUGH" HOLES THERE ARE ALSO HOLES PROVIDED FOR THE LEADS OF DISCRETE COMPONENTS TO PASS THROUGH AND THUS ALLOW ATTACHMENT OF SUCH COMPONENTS TO THE CARD AND ASSOCIATED CIRCUITRY. (THESE HOLES ALSO SOMETIMES SIMULTANEOUSLY SERVE AS "FEED-THROUGH" HOLES.) THE DISTINCTION BETWEEN HOLES THAT SIMPLY SERVE AS "FEED-THROUGH" HOLES AND THOSE THAT ARE FOR COMPONENT LEADS CAN BE MADE BY OBSERVING THE SIZE OF THE FOIL PAD THAT SURROUNDS A HOLE. HOLES FOR THE LEADS OF DISCRETE COMPONENTS ALWAYS HAVE LARGER FOIL PADS AROUND THEM THAN THE PLAIN "FEED-THROUGH" HOLES. THIS IS IMPORTANT TO REMEMBER WHEN INSTALLING DISCRETE COMPONENTS AS SOMETIMES A PLAIN "FEED-THROUGH" HOLE MAY BE CLOSE TO A HOLE THAT THE LEAD OF A DISCRETE COMPONENT IS SUPPOSED TO GO THROUGH. AN ADDITIONAL AID TO DISCERNING THE PROPER HOLES FOR 1/4 WATT RESISTOR LEADS, AND SIMILAR COMPONENTS SUCH AS MOST DIODES, IS TO REMEMBER THAT THE HOLES FOR SUCH COMPONENTS ARE SPACED 1/2 INCH APART.

NOTES ON INSTALLATION OF RESISTORS

TO PREPARE RESISTORS FOR MOUNTING ON THE P.C. CARD USE A PAIR OF NEEDLE POINT PLIERS TO BEND EACH LEAD PERPENDICULAR TO THE BODY OF THE RESISTOR AT A POINT 1/8 OF AN INCH AWAY FROM WHERE THE LEAD JOINS THE RESISTOR BODY. THE BENDING OF THE TWO LEADS SHOULD BE IN THE SAME DIRECTION SO THAT THE PREPARED RESISTOR HAS THE SHAPE OF A "U" WITH THE BODY OF THE RESISTOR FORMING THE BASE OF THE "U" AND THE TIPS OF THE "U" (FORMED BY THE LEADS) BEING 1/2 AN INCH APART. WHEN THIS HAS BEEN DONE THE RESISTOR'S LEADS WILL BE SPACED TO INSERT READILY IN THE HOLES ON THE P.C. CARD. WHEN INSTALLING A RESISTOR, THE TWO LEADS ARE INSERTED IN THE APPROPRIATE HOLES AND THE LEADS PULLED FROM THE BACK OF THE BOARD UNTIL THE RESISTOR BODY IS PULLED UP NEXT TO THE P.C. CARD. THE LEADS ARE THEN BENT OVER ON THE BACK SIDE OF THE CARD AND THE EXCESS LEAD MATERIAL CUT OFF LEAVING ABOUT 1/16 OF AN INCH OF THE LEAD AGAINST THE FOIL PAD. AFTER THE EXCESS LEAD HAS BEEN TRIMMED AWAY THE REMAINING 1/16 INCH OF LEAD IS SOLDERED TO THE P.C. FOIL.

IT IS ALSO IMPORTANT TO ENSURE THAT THE PROPER RESISTOR VALUE IS INSTALLED AT EACH LOCATION. RESISTOR VALUES ARE "COLOR-CODED" BY THREE OR MORE COLOR BANDS ON THE BODY OF THE RESISTOR. THE SEQUENCE OF THE COLORS (STARTING FROM THE BAND NEAREST ONE END OF THE RESISTOR AND READING TOWARDS THE MIDDLE OF THE RESISTOR) ARE GIVEN FOR EACH VALUE OF A RESISTOR USED ON A CARD. (ONLY THE FIRST THREE COLOR BANDS ARE USED TO DENOTE THE ACTUAL RESISTOR VALUE - ANY EXTRA BANDS ON A RESISTOR MAY BE IGNORED BY THE ASSEMBLER AS THEY ARE USED TO DESIGNATE PARAMETERS OTHER THAN THE ACTUAL RESISTOR VALUE.)

NOTES ON INSTALLATION OF DIODES

DIODES ARE PREPARED FOR MOUNTING ON THE P.C. CARD IN A FASHION SIMILAR TO THAT USED FOR RESISTORS. THE BASE OF THE "U" IS THE BODY OF THE DIODE AND THE DISTANCE BETWEEN THE TIPS OF THE "U" MADE BY THE BENT LEADS SHOULD BE 1/2 INCH. DIODES HAVE A COLORED BAND OR A SERIES OF BANDS AT ONE END OF THEIR BODY. THIS BAND MARKS THE CATHODE (NEGATIVE) END OF THE DIODE. THE CATHODE END OF A DIODE IS DENOTED BY A BAND OR BAR ON THE END OF THE DIODE SYMBOL (CONSISTING OF A TRIANGLE POINTING TOWARDS A BAR) THAT WILL BE FOUND AT LOCATIONS ON A P.C. CARD WHERE A DIODE, OR DIODES ARE TO BE INSTALLED. WHEN INSTALLING DIODES IT IS ESSENTIAL THAT THE COMPONENTS ARE INSTALLED WITH THEIR CATHODES AT THE

POSITION INDICATED BY THE ASSEMBLY DRAWING. DIODES ARE POLARITY SENSITIVE DEVICES AND CIRCUITS UTILIZING THEM WILL NOT OPERATE PROPERLY IF THEY ARE INSTALLED INCORRECTLY. DIODES ARE MOUNTED FLUSH TO THE SURFACE OF THE P.C. BOARD THE SAME AS RESISTORS. THE EXCESS LEAD LENGTH IS THEN TRIMMED OFF LEAVING 1/16 INCH TO BE SOLDERED TO THE P.C. FOIL PAD.

GENERAL ASSEMBLY NOTES

AS YOU PERFORM EACH STEP IN THE ASSEMBLY PROCEDURES MAKE A CHECK IN THE BOX PROVIDED TO THE RIGHT OF EACH INSTRUCTION AS A MEANS OF REMEMBERING WHERE YOU ARE IN THE ASSEMBLY PROCESS.

REFER TO THE COMPONENT LOCATION DRAWING PROVIDED FOR EACH CARD AS YOU INSTALL THE COMPONENTS. THE DRAWINGS ARE ESSENTIALLY ON A ONE-TO-ONE SCALE WITH THE ACTUAL PRINTED CIRCUIT CARD TO FACILITATE LOCATING THE PLACEMENT OF EACH COMPONENT.

WORK SLOWLY AND CAREFULLY. MAKE SURE THE SPECIFIED COMPONENT IS INSERTED AT THE PROPER LOCATION AND THAT IT IS ORIENTED IN THE CORRECT DIRECTION. THIS IS ESPECIALLY IMPORTANT WITH INTEGRATED CIRCUITS, DIODES, ELECTROLYTIC CAPACITORS, AND OTHER POLARITY SENSITIVE DEVICES. COMPONENTS INCORRECTLY INSTALLED MAY BE CATASTROPHICALLY DAMAGED WHEN POWER IS APPLIED. IT IS BETTER TO TAKE A FEW EXTRA MINUTES DURING THE ASSEMBLY PROCESS TO INSURE YOU ARE PROCEEDING CORRECTLY THAN TO HURRY AND HAVE TO TRY AND FIND AN ERROR AT A LATER TIME - POSSIBLY AFTER IRREVERSIBLE DAMAGE HAS OCCURED TO A COMPONENT. A CAREFUL ASSEMBLER WILL BE ABLE TO COMPLETE EACH CARD IN THE SCLEBI-8B KIT IN ABOUT TWO HOURS.

STEP-BY-STEP INSTRUCTIONS FOR EACH CARD BEGIN ON THE NEXT PAGE!

SCELBI COMPUTER CONSULTING, INC.

ASSEMBLY INSTRUCTIONS - SCELBI CARD #: 1100-

CPU CARD

DESCRIPTION

THE SCELBI #1100 CPU CARD IS THE PRIMARY CARD IN A SCELBI-8B MINICOMPUTER. THIS CARD CONTAINS A MICROPROCESSOR "CPU-ON-A-CHIP," A NETWORK OF CONTROL AND TIMING LOGIC, AND A MASTER CLOCK SYSTEM. ALL COMPUTER OPERATIONS EMANATE FROM AND TERMINATE AT THIS CARD. THIS CARD PROVIDES SIGNALS THAT CONTROL AND SYNCHRONIZE THE OVERALL OPERATIONS OF ALL OTHER CARDS IN A SCELBI-8B SYSTEM.

NOTE

IF THE CUSTOMER HAS PURCHASED THE OPTION, THE SCELBI #1100 CPU CARD IS SHIPPED WITH A NUMBER OF COMPONENTS ALREADY INSTALLED. THESE COMPONENTS ARE THE NETWORK OF PARTS THAT FORM THE MASTER CLOCK SYSTEM. THE MASTER CLOCK SYSTEM FORMS A CRITICAL PORTION OF A SCELBI-8B MINICOMPUTER AS THE MASTER CLOCK MUST BE CAREFULLY ADJUSTED IN ORDER TO INSURE PROPER COMPUTER OPERATION. FOR THOSE WHO PURCHASED THE OPTION OF HAVING THE MASTER CLOCK INSTALLED AND ADJUSTED AT THE FACTORY, THE RESISTIVE TRIMPOTS USED TO MAKE THE MASTER CLOCK ADJUSTMENTS HAVE BEEN SEALED TO PREVENT THEIR BEING ACCIDENTLY ALTERED. CUSTOMERS ARE CAUTIONED NOT TO TAMPER WITH THE TRIMPOT ADJUSTMENTS ONCE THEY HAVE BEEN SET BY THE FACTORY.

KIT ASSEMBLY

YOU SHOULD REFER TO THE ASSEMBLY DRAWING SHOWN ON THE NEXT PAGE DURING THE ASSEMBLY PROCESS. THE DRAWING IS TO SCALE AND SHOWS THE EXACT LOCATION OF EACH PART ON THE P.C. CARD.

INSTALLATION OF INTEGRATED CIRCUITS

- () INSTALL FOUR TYPE 7400 INTEGRATED CIRCUITS IN THE LOCATIONS LABELED ON THE ASSEMBLY DRAWING AS: Z6, Z13, Z21 AND Z25. WHEN ALL FOUR HAVE BEEN INSTALLED TURN THE CARD OVER AND SOLDER THE PINS ON EACH I.C. TO THEIR FOIL PAD.
- () INSTALL A TYPE 7402 I.C. AT THE LOCATION SPECIFIED FOR Z14 ON THE ASSEMBLY DRAWING. SOLDER THE PINS OF THE INTEGRATED CIRCUIT TO THE CARD.
- () INSTALL AND SOLDER TWO TYPE 7403 INTEGRATED CIRCUITS AT THE LOCATIONS SHOWN FOR Z2 AND Z3.
- () INSTALL AND SOLDER FOUR TYPE 7404 INTEGRATED CIRCUITS AT LOCATIONS Z5, Z12, Z15 AND Z24.

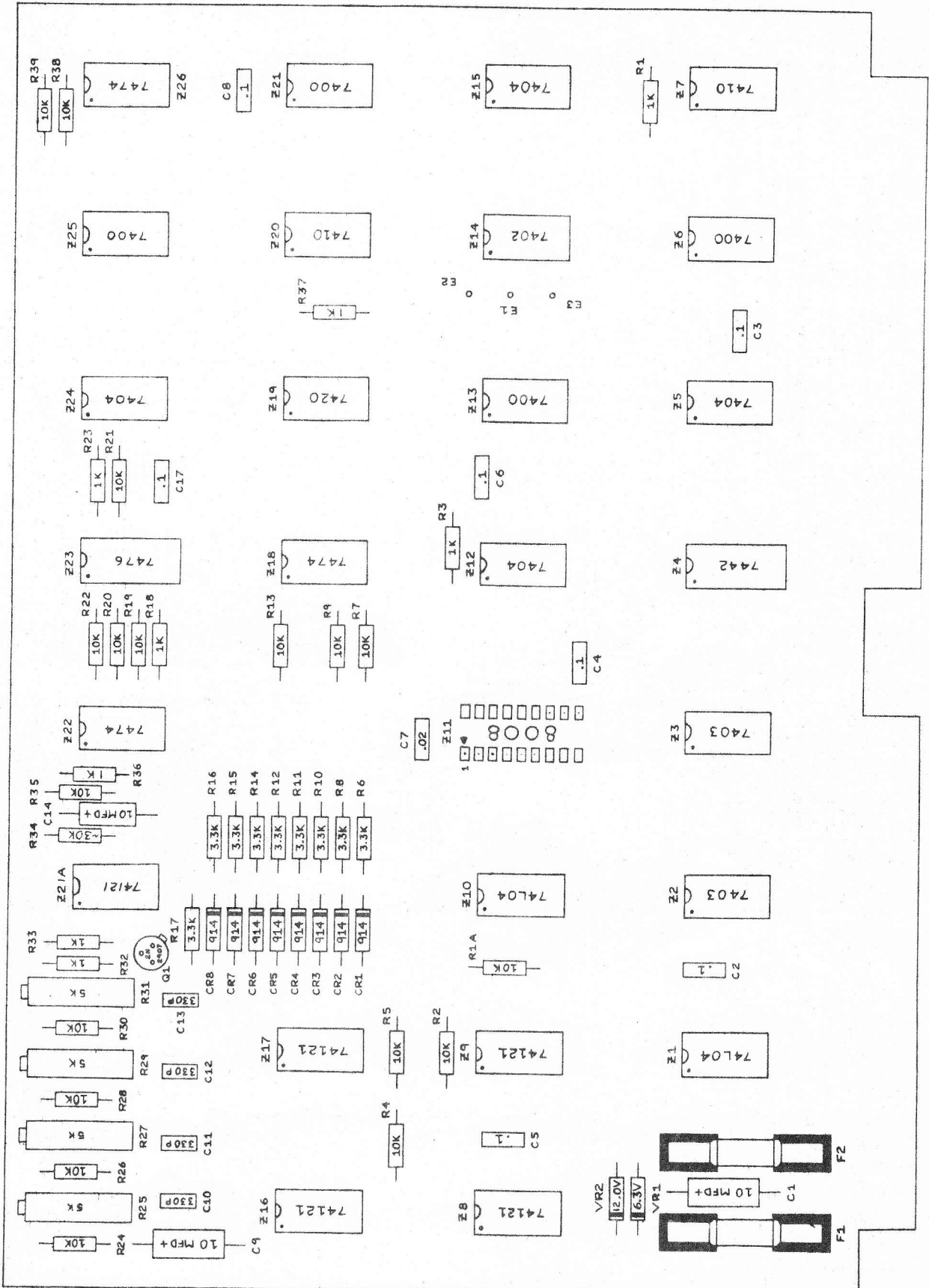

1100 - CPU

- () INSTALL AND SOLDER TWO TYPE 74L04 (LOW POWER) INTEGRATED CIRCUITS AT LOCATIONS Z1 AND Z10.
- () INSTALL AND SOLDER TWO TYPE 7410 INTEGRATED CIRCUITS AT LOCATIONS Z7 AND Z20.
- () INSTALL AND SOLDER A TYPE 7420 I.C. AT LOCATION Z19.
- () INSTALL AND SOLDER A TYPE 7442 I.C. AT LOCATION Z4.
- () INSTALL AND SOLDER THREE TYPE 7474 INTEGRATED CIRCUITS AT LOCATIONS Z18, Z22 AND Z26.
- () INSTALL AND SOLDER A TYPE 7476 I.C. AT LOCATION Z23.
- () INSTALL AND SOLDER FIVE TYPE 74121 INTEGRATED CIRCUITS AT LOCATIONS Z8, Z9, Z16, Z17 AND Z21A.

INSTALLATION OF RESISTORS

- () INSTALL EIGHT 1 K OHM (BRN-BLK-RED) 1/4 WATT RESISTORS AT THE LOCATIONS SHOWN ON THE ASSEMBLY DRAWING FOR: R1, R3, R18, R23, R32, R33, R36 AND R37.
- () INSTALL NINE 3.3 K OHM (OR-OR-RED) 1/4 WATT RESISTORS AT THE LOCATIONS SHOWN FOR R6, R8, R10, R11, R12, R14, R15, R16 AND R17.
- () INSTALL EIGHTEEN 10 K OHM (BRN-BLK-OR) 1/4 WATT RESISTORS AT THE LOCATIONS SHOWN FOR: R1A, R2, R4, R5, R7, R9, R13, R19, R20, R21, R22, R24, R26, R28, R30, R35, R38 AND R39.
- () INSTALL A 33 K OHM (OR-OR-OR) 1/4 WATT RESISTOR AT THE LOCATION SHOWN FOR R34.
- () INSTALL FOUR 5 K OHM TRIMPOTS AT THE LOCATIONS SHOWN FOR R25, R27, R29 AND R31.

INSTALLATION OF DIODES

- () INSTALL EIGHT COMPUTER DIODES AT THE LOCATIONS SHOWN FOR: CR1 THROUGH CR8.
- () INSTALL ONE 6.3 VOLT ZENER DIODE AT THE LOCATION SHOWN FOR VR1. BE SURE AND OBSERVE CORRECT POLARITY AS INDICATED ON THE DRAWING.
- () INSTALL ONE 12.0 VOLT ZENER DIODE AT THE LOCATION SHOWN FOR VR2. OBSERVE CORRECT POLARITY!

TRANSISTOR INSTALLATION

- () INSTALL A TYPE 2N2907 TRANSISTOR AT THE LOCATION SHOWN ON THE ASSEMBLY DRAWING FOR Q1. THE BODY OF THE TRANSISTOR SHOULD BE SPACED ABOUT 1/8 INCH AWAY FROM THE P.C. CARD. AS AN AID IN MAINTAINING THIS DISTANCE AS THE TRANSISTOR IS INSTALLED, PLACE A PAPER MATCH STICK UNDER THE TRANSISTOR WHEN THE TRANSISTOR LEADS ARE

FIRST INSERTED IN THEIR HOLES. PUSH THE TRANSISTOR LEAD THROUGH THE CARD UNTIL THE BODY IS TOUCHING THE MATCH STICK. THEN, TURN THE CARD OVER, BEND THE TRANSISTOR LEADS AGAINST THEIR RESPECTIVE FOIL PADS, TRIM THE EXCESS LEAD MATERIAL OFF LEAVING 1/16 INCH OF LEAD TO BE SOLDERED TO THE FOIL PAD. SOLDER THE LEADS OF THE TRANSISTOR. THEN, REMOVE THE MATCHSTICK THAT WAS USED AS A SPACER. NOTE: WHEN INSTALLING THE TRANSISTOR BE SURE THAT THE SMALL TAB ON THE BODY OF THE TRANSISTOR (DENOTING THE EMITTER JUNCTION LEAD OF THE DEVICE) IS ORIENTED IN THE DIRECTION SHOWN ON THE ASSEMBLY DRAWING.

INSTALLATION OF CAPACITORS

- () INSTALL THREE 10 MFD ELECTROLYTIC CAPACITORS IN THE POSITIONS LABELED ON THE ASSEMBLY DRAWING AS: C1, C9 AND C14. BE CERTAIN THAT THE POSITIVE (+) END OF THE CAPACITOR IS ORIENTED IN THE SAME DIRECTION AS THAT SHOWN ON THE DRAWING (AND INDICATED ON THE P.C. CARD). AS EACH CAPACITOR IS INSTALLED BEND THE LEADS DOWN ONTO THEIR FOIL PADS ON THE BACK SIDE OF THE BOARD AND TRIM OFF THE EXCESS LEAD. THE SOLDER EACH CAPACITOR LEAD TO IT'S FOIL CONNECTION POINT.
- () INSTALL SEVEN .1 UFD DISK CAPACITORS IN THE POSITIONS LABELED ON THE ASSEMBLY DRAWING AS: C2, C3, C4, C5, C6, C8 AND C17. TRIM THE LEADS AND SOLDER THE CAPACITORS IN PLACE.
- () INSTALL AND SOLDER IN PLACE A .02 UFD DISK CAPACITOR AT THE LOCATION SPECIFIED ON THE ASSEMBLY DRAWING FOR C7.
- () INSTALL AND SOLDER IN PLACE FOUR 330 PF DISK CAPACITORS AT THE LOCATIONS FOR: C10, C11, C12 AND C13.

INSTALLATION OF FUSE CLIPS

- () INSTALL THE FOUR P.C. MOUNTING FUSE CLIPS IN THE POSITIONS SHOWN TO HOLD F1 AND F2. INSERT THE TWO TABS ON THE BASE OF EACH CLIP INTO THE HOLES PROVIDED, BEND THE TABS SLIGHTLY AGAINST THE FOIL ON THE OTHER SIDE OF THE CARD TO HOLD THEM IN PLACE AND THEN SOLDER EACH TAB TO THE FOIL. ENSURE THAT THE CLIPS LINE UP SO THAT A FUSE WILL SEAT PROPERLY WHEN INSTALLED.

INITIAL INSPECTION AND TESTING

- () AT THIS TIME CAREFULLY INSPECT BOTH SIDES OF THE BOARD TO ASCERTAIN THAT THERE ARE NOT ANY SOLDER SHORTS BETWEEN P.C. FOIL LANDS. BE ESPECIALLY OBSERVANT ON THE COMPONENT SIDE OF THE CARD AROUND THE I.C. PINS. REMOVE ANY SOLDER SHORTS THAT ARE FOUND.
- () INSTALL A 0.75 AMP TYPE 8AG FUSE IN THE FUSE CLIPS FOR F1.
- () TEMPORARILY "JUMPER" THE FUSE CLIPS FOR F2 WITH A PIECE OF WIRE OR A LENGTH OF SOLDER.
- () USE AN OHM METER TO MAKE THE FOLLOWING MEASUREMENTS:

METER BETWEEN PINS A1 AND A3 OF THE CARD CONNECTOR - AND THEN REVERSE THE METER LEADS TO OBTAIN A SECOND READING. THE READING IN BOTH DIRECTIONS SHOULD BE GREATER THAN FIVE (5) OHMS. (ONE READING WILL TYPICALLY BE SEVERAL TIMES HIGHER THAN THE OTHER.) IF THE READINGS ARE LESS THAN 5 OHMS LOOK FOR SOLDER SHORTS BETWEEN THE +5 VOLT SUPPLY LINES AND THE COMMON RETURN LINES ON THE CARD.

NOW REPEAT THE ABOVE READINGS BETWEEN PINS A3 AND A5 OF THE CARD CONNECTOR. THIS TIME THE READING IN ONE DIRECTION SHOULD BE VERY HIGH (GREATER THAN 50 K OHMS) AND THE READING WITH THE METER LEADS REVERSED SHOULD BE GREATER THAN FIVE (5) OHMS. IF THIS IS NOT THE CASE, LOOK FOR SOLDER SHORTS BETWEEN THE -9 VOLT SUPPLY LINES AND THE COMMON RETURN LINES ON THE CARD.

FINALLY, TAKE SIMILAR READINGS BETWEEN PINS A1 AND A5 OF THE CARD. THE READING IN ONE DIRECTION SHOULD BE MORE THAN 50 K OHMS, AND IN THE OTHER MORE THAN FIVE (5) OHMS. IF NOT, LOOK FOR SOLDER SHORTS BETWEEN THE +5 VOLT AND -9 VOLT SUPPLY LINES ON THE CARD.

- () REMOVE THE JUMPER FROM THE FUSE CLIPS AT F2 AND INSTALL A 1/8 AMPERE TYPE 8AG FUSE.

ADJUSTING THE MASTER CLOCK

IF YOU PURCHASED A CPU CARD THAT DID NOT HAVE THE MASTER CLOCK CIRCUIT INSTALLED AND ADJUSTED YOU SHOULD REFER TO THE APPENDIX ON THE NEXT PAGE AND PERFORM THE CLOCK CIRCUIT ADJUSTMENTS BEFORE GOING FURTHER. IF YOU PURCHASED A CPU CARD WITH THE CLOCK CIRCUITRY ALREADY INSTALLED AND ADJUSTED YOU MAY PROCEED DIRECTLY TO THE NEXT STEP.

INSTALLATION OF THE '8008' INTEGRATED CIRCUIT

- () BEFORE INSTALLING THE 8008 INTEGRATED CIRCUIT TAKE A SHORT PIECE OF WIRE AND INSTALL A JUMPER BETWEEN THE FOIL PADS ON THE CARD MARKED "E1" AND "E2" (NEXT TO I.C. Z14). MAKE SURE THE JUMPER DOES NOT SHORT TO ANY OF THE FOIL LANDS THAT IT CROSSES OVER.
- () THE 8008 "CPU-ON-A-CHIP" REQUIRES AN 18 PIN SOCKET WHICH MAY BE READILY FASHIONED USING "MOLEX" (RTM) PINS. THE 8008 SHOULD BE INSTALLED IN ITS SOCKET AT Z11 MAKING SURE THAT THE SMALL DOT OR ARROW WHICH DESIGNATES PIN #1 ON THE I.C. IS ORIENTED AS SHOWN ON THE ASSEMBLY DRAWING. WHEN INSTALLING THE '8008' TAKE EXTREME CARE TO ENSURE THAT EACH PIN FITS INTO IT'S INDIVIDUAL CLIP OF THE "MOLEX" SOCKET. DO NOT FORCE THE DEVICE INTO IT'S SOCKET AS THIS MAY SUBSEQUENTLY BEND AND POSSIBLY BREAK I.C. PINS. WHEN THE I.C. IS FULLY SEATED IN THE SOCKET CHECK TO SEE THAT NONE OF THE MOLEX PINS ARE SHORTING TO AN ADJACENT PIN.

FINAL TESTING

FINAL TESTING OF THE CARD MUST BE DONE WHEN THE CARD IS INSTALLED IN A SCLEBI-8B MINICOMPUTER SYSTEM.

ADJUSTING THE MASTER CLOCK CIRCUITRY ON THE SCLEBI #1100 CPU CARD

THE MASTER CLOCK CIRCUITRY FOR THE SCLEBI-8B MINI-COMPUTER IS ON THE SCLEBI #1100 CPU CARD. THIS CIRCUITRY MUST BE ADJUSTED CORRECTLY OR THE UNIT WILL NOT FUNCTION PROPERLY. TO ADJUST THE MASTER CLOCK CIRCUITRY YOU WILL NEED THE FOLLOWING INSTRUMENTS.

1. A FREQUENCY COUNTER.
2. A GOOD OSCILLOSCOPE, EITHER A DUAL TRACE, OR A SINGLE TRACE UNIT THAT CAN BE "EXTERNALLY" TRIGGERED.

ADJUSTMENT SETUP

CONNECT A +5 VOLT SUPPLY BETWEEN PINS A1 (+) AND A3 (COMMON) OF THE CPU CARD. (THE CARD MAY BE PLACED ON YOUR WORK BENCH - IT DOES NOT HAVE TO BE INSTALLED IN A CHASSIS OR SYSTEM.) THE +5 VOLT SUPPLY SHOULD BE CONTROLLED BY A SWITCH SO THAT POWER CAN BE APPLIED AND REMOVED AT WILL.

CONNECT THE "A" TRACE OF A DUAL TRACE SCOPE AND SET THE SCOPE TO TRIGGER ON SWEEP "A," OR, IF A SINGLE TRACE SCOPE IS BEING USED ATTACH THE "EXTERNAL" TRIGGER LEAD TO PIN 6 OF I.C. 28. (THIS SIGNAL CAN ALSO BE READILY ACCESSED AT THE LEFT LEAD OF RESISTOR R2.) THIS SIGNAL WILL BE DESIGNATED "CLOCK PHASE 1" FOR THIS DISCUSSION.

CONNECT A FREQUENCY COUNTER TO PIN 6 OF Z17 (OR PICK UP THE SIGNAL ON THE RIGHT LEAD OF RESISTOR R1.) THIS SIGNAL IS DESIGNATED "CLOCK PHASE 2." IF YOU ARE USING A DUAL TRACE SCOPE YOU MAY ALSO CONNECT TRACE "B" TO THIS POINT. OTHERWISE, USE THIS POINT TO EXAMINE "CLOCK PHASE 2" WHEN NECESSARY DURING THE ADJUSTMENT PROCEDURE.

NATURALLY, BOTH THE OSCILLOSCOPE AND THE FREQUENCY COUNTER SHOULD HAVE THEIR COMMON TERMINALS CONNECTED TO THE COMMON POINT ON THE CPU CARD (AT PIN A3.)

ADJUSTMENT PROCEDURE

THE MASTER CLOCK CIRCUIT HAS A "SELF STARTING" NETWORK CONSISTING OF RESISTOR R24 AND CAPACITOR C9. IN ORDER FOR THE CIRCUIT TO START TWO CONDITIONS MUST BE MET. FIRST, THE POWER SUPPLY VOLTAGE MUST COME ON RAPIDLY WHEN POWER IS APPLIED TO THE CARD, AND SECOND, THE CLOCK CIRCUIT MUST BE ADJUSTED WITHIN ITS OSCILLATING RANGE.

THE FIRST STEP IN THE ADJUSTMENT PROCEDURE IS TO APPLY POWER TO THE CARD AND OBSERVE THAT A SIGNAL APPEARS AT "CLOCK PHASE 1." IF A SIGNAL DOES NOT APPEAR, TURN THE POWER OFF, ADJUST TRIMPOTS R25 AND R27 SEVERAL TURNS AND THE RE-APPLY POWER. CONTINUE THIS PROCEDURE UNTIL A SIGNAL APPEARS AT "CLOCK PHASE 1" WHEN POWER IS APPLIED.

N O T I C E

CUSTOMER'S WHO PROVIDE THEIR OWN POWER SUPPLIES SHOULD BE CAUTIONED THAT SOME POWER SUPPLIES, WHEN TURNED ON BY A SWITCH IN THE A.C. LINE, WILL NOT BUILD UP TO THE PROPER D.C. LEVEL AT A FAST ENOUGH RATE TO ACTIVATE THE CLOCK CIRCUIT. IN SUCH CASES, A SWITCH SHOULD BE INSTALLED IN THE D.C. SUPPLY LINE TO THE COMPUTER. AFTER THE POWER SUPPLY HAS BEEN INITIALLY TURNED ON BY THE A.C. LINE SWITCH, AND HAS HAD TIME TO BUILD UP THE PROPER VOLTAGE LEVELS, THE D.C. SWITCH CAN BE USED TO CONNECT THE SUPPLY VOLTAGES TO THE COMPUTER.

ONCE A STEADY SIGNAL HAS APPEARED AT "CLOCK PHASE 1, LOOK FOR A SIGNAL AT "CLOCK PHASE 2." IF NECESSARY, ADJUST TRIMPOTS R29 AND R31 UNTIL A SIGNAL APPEARS.

WHEN A SIGNAL IS PRESENT AT BOTH "CLOCK PHASE 1" AND "CLOCK PHASE 2" ONE MAY PROCEED TO MAKE THE FINE ADJUSTMENTS TO THE CLOCK CIRCUITRY.

TO MAKE THE FINE ADJUSTMENTS GO BACK AND CAREFULLY ADJUST TRIMPOTS R25 AND R27 UNTIL "CLOCK PHASE 1" IS HIGH FOR APPROXIMATELY 850 NANO-SECONDS AND LOW FOR 1150 NANO-SECONDS. ONCE THE SIGNAL IS CLOSE TO THIS RANGE OBSERVE THE FREQUENCY COUNTER AND CAREFULLY TWEAK THE TRIMPOTS FOR A FREQUENCY READING OF 500 KILOHERTZ WHILE MAINTAINING THE INDICATED HIGH/LOW RATIOS AS CLOSELY AS POSSIBLE. SET THE FREQUENCY AS CLOSE TO 500 KILOHERTZ AS PRACTICAL - AT LEAST WITHIN PLUS OR MINUS 5 KHZ., PREFERABLY WITHIN SEVERAL KILOHERTZ.

NEXT, WITH THE SCOPE BEING TRIGGERED BY "CLOCK PHASE 1," OBSERVE "CLOCK PHASE 2." USE TRIMPOTS R29 AND R31 TO OBTAIN THE FOLLOWING CONDITIONS. "CLOCK PHASE 2" SHOULD GO HIGH ABOUT 200 NANO-SECONDS AFTER THE FALL OF "CLOCK PHASE 1," AND SHOULD REMAIN HIGH FOR APPROXIMATELY 550 NANO-SECONDS. WHEN THIS CONDITION IS MET, AND "CLOCK PHASE 1" HAS BEEN PROPERLY ADJUSTED, THE DISTANCE BETWEEN THE FALL OF "CLOCK PHASE 2" AND THE RISE OF "CLOCK PHASE 1" WILL BE ABOUT 400 NANO-SECONDS.

NOTE! IF AT ANY TIME DURING THE ADJUSTMENT PROCEDURE THE CLOCK SIGNAL(S) DISAPPEAR IT WILL BE NECESSARY TO RE-APPLY POWER TO RESTART THE CLOCK.

WHEN "CLOCK PHASE 1" AND "CLOCK PHASE 2" HAVE BEEN ADJUSTED FOR THE WAVEFORMS AS DESCRIBED, YOU SHOULD ALLOW THE CIRCUIT TO OPERATE FOR APPROXIMATELY 30 MINUTES AND THEN RECHECK THE FREQUENCY. YOU MAY MAKE MINOR ADJUSTMENTS TO BRING THE FREQUENCY TO 500 KHZ. AFTER THE CIRCUIT HAS BEEN OPERATING FOR THIS PERIOD. THIS COMPLETES THE MASTER CLOCK CIRCUITRY ADJUSTMENT PROCEDURE.

A SUMMARY OF THE ADJUSTMENT LIMITS AND A PICTORIAL OF THE WAVEFORMS AND TIMING RELATIONSHIPS IS SHOWN ON THE NEXT PAGE.

CLOCK CIRCUITRY ADJUSTMENT

SUMMARY

CLOCK PERIOD (Phase 1 or 2): 2,000 Nano-seconds \pm 100 Nano-seconds
Minimum pulse width of CLOCK PHASE 1: 700 Nano-seconds
Minimum pulse width of CLOCK PHASE 2: 550 Nano-seconds
Minimum delay from fall of PHASE 1 to rise of PHASE 2: 200 Nano-seconds
Minimum delay from fall of PHASE 2 to rise of PHASE 1: 400 Nano-seconds
Minimum delay from fall of PHASE 1 to fall of PHASE 2: 700 Nano-seconds
Maximum delay from fall of PHASE 1 to fall of PHASE 2: 1,100 Nano-sec.

REPRESENTATIVE WAVEFORMS

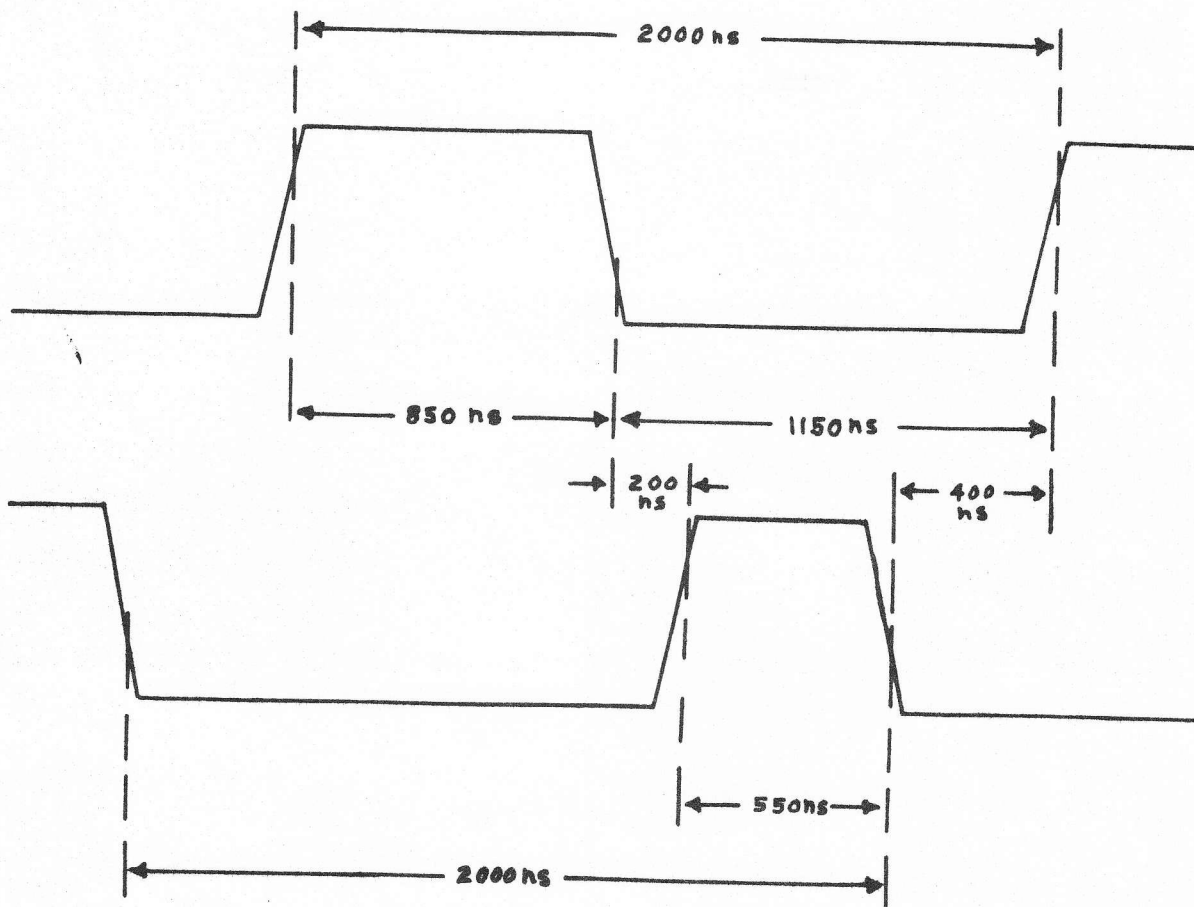

SCELBI COMPUTER CONSULTING, INC.

ASSEMBLY INSTRUCTIONS - SCELBI CARD #: 1101-

DBB & OUTPUT CARD

DESCRIPTION

THE SCELBI #1101 DBB & OUTPUT CARD CONTAINS MEMORY ADDRESS AND STATE CONTROL LATCHES AND LOGIC FOR SELECTING BANKS OF MEMORY WORDS. IN ADDITION THE CARD CONTAINS MULTIPLEXING LOGIC FOR SELECTING OUTPUT PORTS. WHILE THE CARD IS CAPABLE OF SELECTING 16 DIFFERENT OUTPUT PORTS, IF IT IS INSTALLED IN A STANDARD SCELBI-8B CHASSIS ONLY EIGHT OF THE OUTPUT PORTS WILL BE WIRED TO THE I/O CONNECTORS ON THE BACK OF THE CHASSIS UNIT.

KIT ASSEMBLY

YOU SHOULD REFER TO THE ASSEMBLY DRAWING SHOWN ON THE NEXT PAGE DURING THE ASSEMBLY PROCESS. THE DRAWING IS TO SCALE AND SHOWS THE EXACT LOCATION OF EACH PART ON THE P.C. CARD.

INSTALLATION OF INTEGRATED CIRCUITS

- () INSTALL TWO TYPE 7400 INTEGRATED CIRCUITS IN THE LOCATIONS LABELED ON THE ASSEMBLY DRAWING AS: Z13 & Z16A. WHEN THEY HAVE BEEN INSTALLED TURN THE CARD OVER AND SOLDER THE PINS ON THE I.C. TO THEIR FOIL PAD.
- () INSTALL FOUR TYPE 7402 INTEGRATED CIRCUITS AT THE LOCATIONS SPECIFIED FOR Z1, Z2, Z4 AND Z5. THEN SOLDER THE PINS OF THE INTEGRATED CIRCUITS TO THE CARD FOIL.
- () INSTALL AND SOLDER TWO TYPE 7416 INTEGRATED CIRCUITS AT THE LOCATIONS SHOWN FOR Z10 AND Z16.
- () INSTALL AND SOLDER TWO TYPE 7417 INTEGRATED CIRCUITS AT THE LOCATIONS SHOWN FOR Z3 AND Z15.
- () INSTALL AND SOLDER FOUR TYPE 7442 INTEGRATED CIRCUITS AT THE LOCATIONS SHOWN FOR Z11, Z12, Z14 AND Z17.
- () INSTALL AND SOLDER FOUR TYPE 7475 INTEGRATED CIRCUITS AT THE LOCATIONS SHOWN FOR Z6, Z7, Z8 AND Z9.

INSTALLATION OF RESISTORS

- () INSTALL FIFTY-FOUR 1 K OHM (BRN-BLK-RED) 1/4 WATT RESISTORS AT THE LOCATIONS SHOWN ON THE ASSEMBLY DRAWING FOR R1 THROUGH R52, AS WELL AS R54 AND R55. (R53 DESIGNATION NOT USED.)

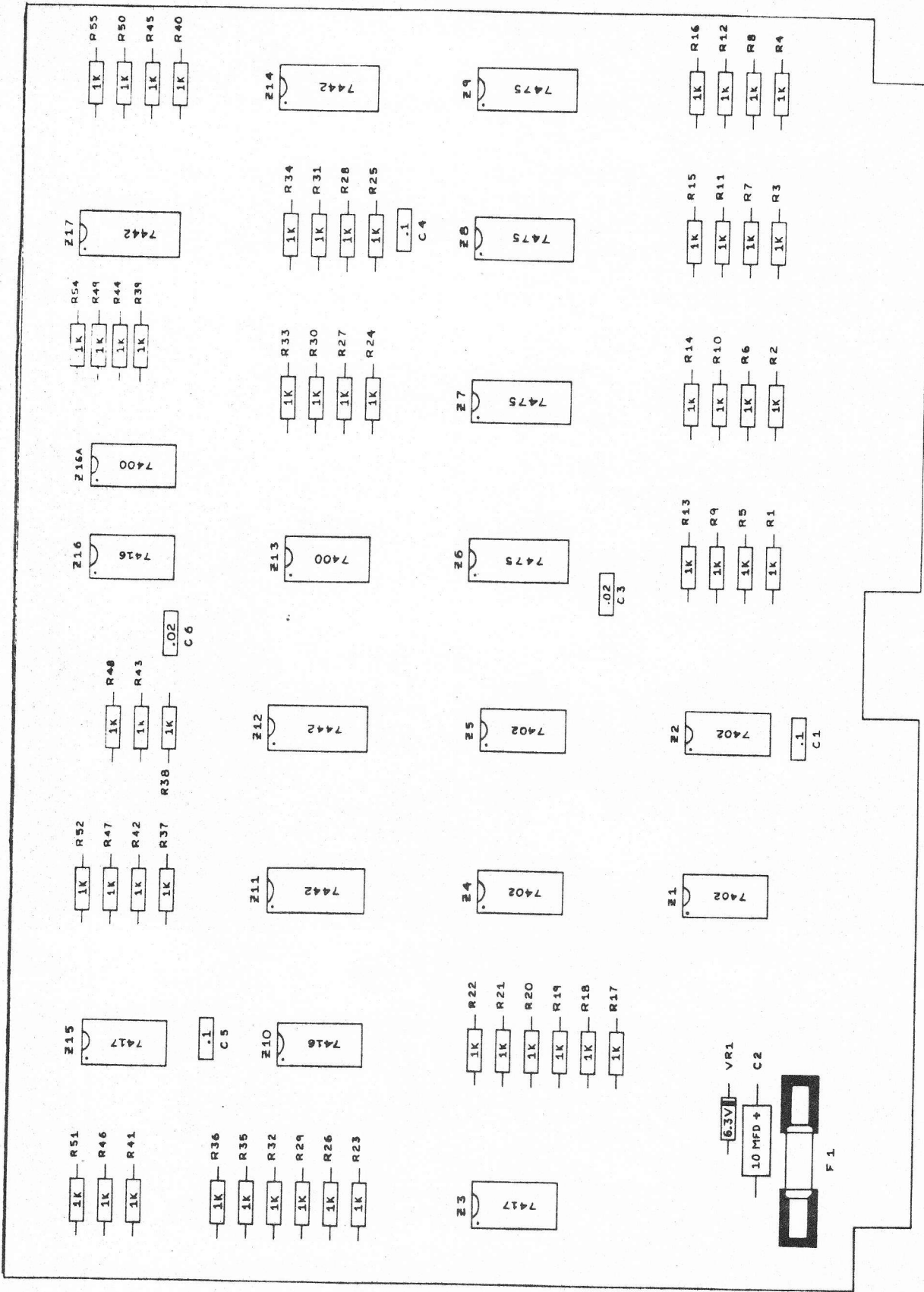

1101 - DBB

INSTALLATION OF DIODES

- () INSTALL ONE 6.3 VOLT ZENER DIODE AT THE LOCATION SHOWN FOR VR1. BE SURE AND OBSERVE CORRECT POLARITY AS INDICATED ON THE DRAWING.

INSTALLATION OF CAPACITORS

- () INSTALL ONE 10 MFD ELECTROLYTIC CAPACITOR IN THE POSITION LABELED ON THE ASSEMBLY DRAWING FOR C2. BE CERTAIN THAT THE POSITIVE (+) END OF THE CAPACITOR IS ORIENTED IN THE SAME DIRECTION AS THAT SHOWN ON THE DRAWING AND INDICATED ON THE P.C. CARD.
- () INSTALL THREE .1 UFD DISK CAPACITORS IN THE POSITIONS LABELED ON THE ASSEMBLY DRAWING AS: C1, C4 AND C5.
- () INSTALL TWO .02 UFD DISK CAPACITORS AT THE LOCATIONS IDENTIFIED ON THE ASSEMBLY DRAWING FOR C3 AND C6.

INSTALLATION OF FUSE CLIPS

- () INSTALL THE TWO P.C. MOUNTING FUSE CLIPS IN THE POSITIONS SHOWN TO HOLD FUSE F1. INSERT THE TWO TABS ON THE BASE OF EACH CLIP INTO THE HOLES PROVIDED FOR EACH CLIP, BEND THE TABS SLIGHT AGAINST THE FOIL ON THE OTHER SIDE OF THE BOARD TO HOLD THEM IN PLACE AND THEN SOLDER EACH TAB TO THE FOIL. ENSURE THAT THE CLIPS LINE UP SO THAT A FUSE WILL SEAT PROPERLY WHEN INSTALLED.
- () INSTALL A 1.0 AMPERE TYPE 8AG FUSE IN THE FUSE CLIPS FOR F1.

INITIAL INSPECTION AND TESTING

- () AT THIS TIME CAREFULLY INSPECT BOTH SIDES OF THE BOARD TO ASCERTAIN THAT THERE ARE NOT ANY SOLDER SHORTS BETWEEN P.C. FOIL LANDS. BE ESPECIALLY OBSERVANT ON THE COMPONENT SIDE OF THE CARD AROUND THE I.C. PINS. REMOVE ANY SOLDER SHORTS THAT ARE FOUND.
- () USE AN OHM METER TO MAKE THE FOLLOWING MEASUREMENTS:

METER BETWEEN PINS A1 AND A3 OF THE CARD CONNECTOR - AND THEN REVERSE THE METER LEADS TO OBTAIN A SECOND READING. THE READING IN BOTH DIRECTIONS SHOULD BE GREATER THAN FIVE (5) OHMS. (ONE READING WILL TYPICALLY BE SEVERAL TIMES HIGHER THAN THE OTHER.) IF THE READINGS ARE LESS THAN FIVE OHMS LOOK FOR SOLDER SHORTS BETWEEN THE +5 VOLT SUPPLY LINES AND THE COMMON RETURN LINES ON THE CARD.

FINAL TESTING

FINAL TESTING OF THE CARD MUST BE DONE WHEN THE CARD IS INSTALLED IN A SCELBI-8B MINICOMPUTER SYSTEM.

SCELBI COMPUTER CONSULTING, INC.

ASSEMBLY INSTRUCTIONS - SCELBI CARD #: 1102-

INPUT CARD

DESCRIPTION

THE SCELBI #1102 INPUT CARD CONTAINS MULTIPLEXING LOGIC WHICH SELECTS THE INPUT TO THE CENTRAL PROCESSOR UNIT. THE CARD ALLOWS THE INPUT TO THE "CPU" TO ARRIVE FROM THE MEMORY BANKS, THE CONSOLE SWITCHES (WHICH ARE USED TO ALLOW CONTROL OF THE COMPUTER BY MANUAL MEANS), OR ANY ONE OF SIX DIFFERENT INPUT PORTS.

KIT ASSEMBLY

YOU SHOULD REFER TO THE ASSEMBLY DRAWING SHOWN ON THE NEXT PAGE DURING THE ASSEMBLY PROCESS. THE DRAWING IS TO SCALE AND SHOWS THE EXACT LOCATION OF EACH PART ON THE P.C. CARD.

INSTALLATION OF INTEGRATED CIRCUITS

- () INSTALL A TYPE 7400 INTEGRATED CIRCUIT IN THE LOCATION LABELED ON THE ASSEMBLY DRAWING AS Z5. WHEN IT HAS BEEN INSTALLED TURN THE CARD OVER AND SOLDER THE PINS ON THE I.C. TO THEIR FOIL PAD.
- () INSTALL A TYPE 7404 INTEGRATED CIRCUIT AT THE LOCATION SPECIFIED FOR Z11. THEN SOLDER THE PINS OF THE I.C. TO THE CARD.
- () INSTALL AND SOLDER A TYPE 7410 I.C. AT THE LOCATION SHOWN FOR Z6.
- () INSTALL AND SOLDER EIGHT TYPE 74151 INTEGRATED CIRCUITS AT THE LOCATIONS SHOWN FOR: Z1, Z2, Z3, Z4, Z7, Z8, Z9 AND Z10.

INSTALLATION OF RESISTORS

- () INSTALL SIXTY FIVE 10 K OHM (BRN-BLK-OR) 1/4 WATT RESISTORS AT THE LOCATIONS SHOWN ON THE ASSEMBLY DRAWING FOR R1 THROUGH R65.

INSTALLATION OF DIODES

- () INSTALL ONE 6.3 VOLT ZENER DIODE AT THE LOCATION SHOWN FOR VR1. BE SURE AND OBSERVE CORRECT POLARITY AS INDICATED ON THE DRAWING.

INSTALLATION OF CAPACITORS

- () INSTALL ONE 10 MFD ELECTROLYTIC CAPACITOR IN THE POSITION LABELED ON THE DRAWING FOR C1. BE CERTAIN THAT THE POSITIVE (+) END OF THE CAPACITOR IS ORIENTED IN THE SAME DIRECTION AS THAT SHOWN ON

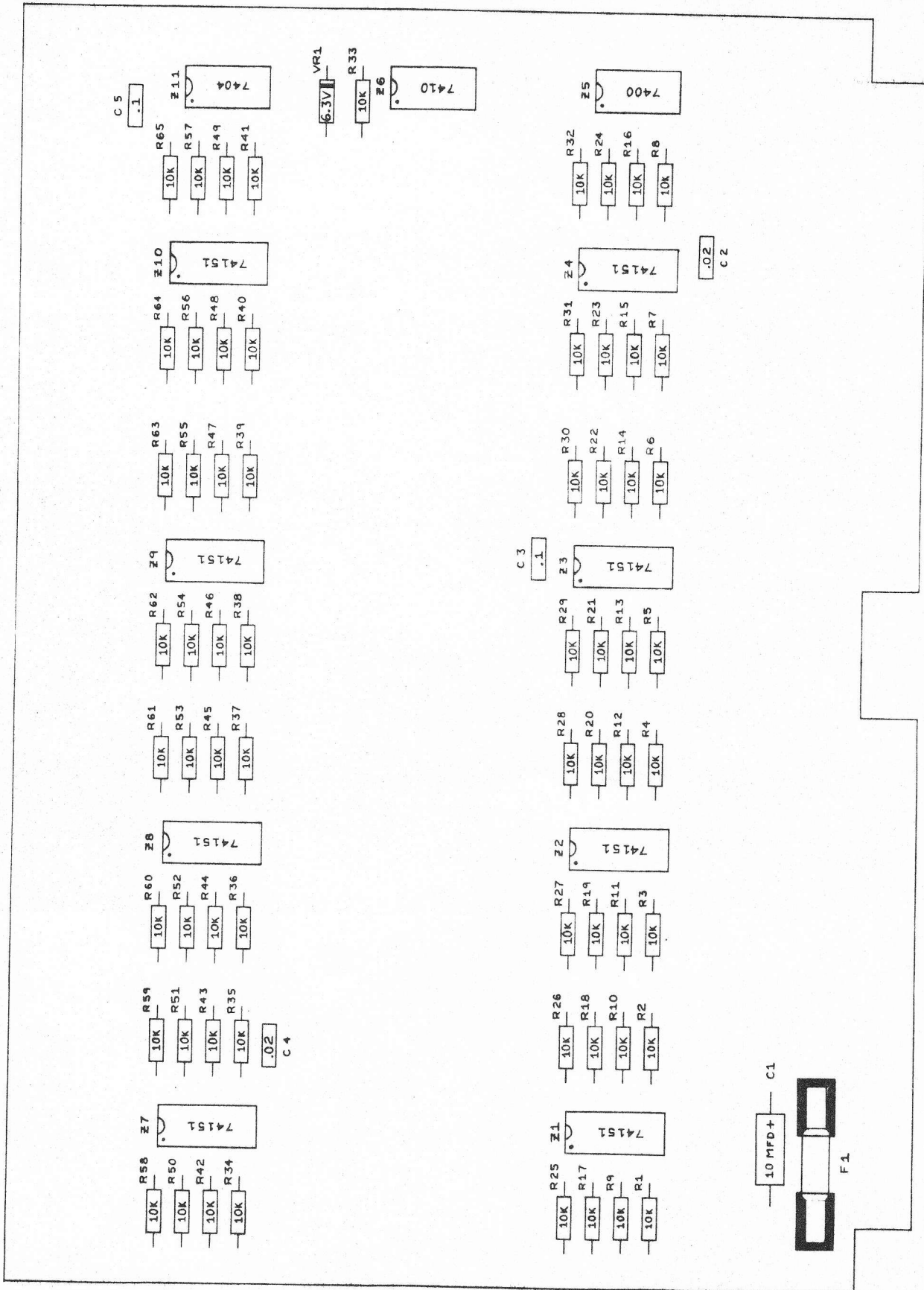

1102 - INPUT

THE DRAWING AND INDICATED ON THE P.C. CARD.

- () INSTALL TWO .1 UFD DISK CAPACITORS IN THE POSITIONS LABELED ON THE ASSEMBLY DRAWING AS: C3 AND C5.
- () INSTALL TWO .02 UFD DISK CAPACITORS IN THE POSITIONS LABELED ON THE ASSEMBLY DRAWING AS: C2 AND C4.

INSTALLATION OF FUSE CLIPS

- () INSTALL THE TWO P.C. MOUNTING FUSE CLIPS IN THE POSITIONS SHOWN TO HOLD FUSE F1. INSERT THE TWO TABS ON THE BASE OF EACH CLIP INTO THE HOLES PROVIDED, BEND THE TABS SLIGHTLY AGAINST THE FOIL ON THE OTHER SIDE OF THE CARD TO HOLD THEM IN PLACE AND THEN SOLDER EACH TAB TO THE FOIL. ENSURE THAT THE CLIPS LINE UP SO THAT A FUSE WILL SEAT PROPERLY WHEN INSTALLED.

INITIAL INSPECTION AND TESTING

- () AT THIS TIME CAREFULLY INSPECT BOTH SIDE OF THE BOARD TO ASCERTAIN THAT THERE ARE NOT ANY SOLDER SHORTS BETWEEN P.C. FOIL LANDS. BE ESPECIALLY OBSERVANT ON THE COMPONENT SIDE OF THE CARD AROUND THE I.C. PINS. REMOVE ANY SOLDER SHORTS THAT ARE FOUND.
- () INSTALL A 3/8 AMPERE TYPE 8AG FUSE IN THE FUSE CLIPS FOR F1.
- () USE AN OHM METER TO MAKE THE FOLLOWING MEASUREMENTS:

METER BETWEEN PINS A1 AND A3 OF THE CARD CONNECTOR - AND THE REVERSE THE METER LEADS TO OBTAIN A SECOND READING. THE READING IN BOTH DIRECTIONS SHOULD BE GREATER THAN FIVE (5) OHMS. (ONE READING WILL TYPICALLY BE SEVERAL TIMES HIGHER THAN THE OTHER.) IF THE READINGS ARE LESS THAN FIVE OHMS LOOK FOR SOLDER SHORTS BETWEEN THE +5 VOLT SUPPLY LINES AND THE COMMON RETURN LINES ON THE CARD.

FINAL TESTING

FINAL TESTING OF THE CARD MUST BE DONE WHEN THE CARD IS INSTALLED IN A SCELBI-8B MINICOMPUTER CHASSIS UNIT.

SCELBI COMPUTER CONSULTING, INC.

ASSEMBLY INSTRUCTIONS - SCELBI CARD #: 1104-

FRONT PANEL CARD

DESCRIPTION

THE SCELBI #1104 FRONT PANEL CARD HAS BEEN SPECIALLY DESIGNED TO ALLOW A SCELBI-8B USER TO MONITOR THE OPERATION OF A SCELBI-8B MINI-COMPUTER. THE CARD CONTAINS AN ARRAY OF LOGIC CIRCUITRY AND LONG LASTING SOLID STATE LIGHT EMITTING EODIODES WHICH ALLOW THE OPERATOR TO DISPLAY THE CONTENTS OF MEMORY LOCATIONS, INTERNAL CPU REGISTER CONTENTS, CRITICAL CYCLE STATES, AND THE GENERAL STATUS OF THE CPU AND I/O OPERATIONS. THE CARD ALOS CONTAINS POWER SUPPLY VOLTAGE MONITOR INDICATORS.

KIT ASSEMBLY

YOU SHOULD REFER TO THE ASSEMBLY DRAWING SHOWN ON THE NEXT PAGE DURING THE ASSEMBLY PROCESS. THE DRAWING IS TO SCALE AND SHOWS THE EXACT LOCATION OF EACH PART ON THE P.C. CARD.

INSTALLATION OF INTEGRATED CIRCUITS

- () INSTALL TWO TYPE 74L04 (LOW POWER) INTEGRATED CIRCUITS IN THE LOCATIONS LABELED ON THE ASSEMBLY DRAWING AS: Z1 AND Z3. WHEN THE TWO HAVE BEEN INSTALLED TURN THE CARD OVER AND SOLDER THE PINS ON EACH I.C. TO THEIR FOIL PAD.
- () INSTALL THREE TYPE 7416 INTEGRATED CIRCUITS AT THE LOCATIONS SPECIFIED FOR: Z5, Z6 AND Z7. THEN SOLDER THE PINS OF THE INTEGRATED CIRCUITS TO THE CARD.
- () INSTALL AND SOLDER TWO TYPE 7475 INTEGRATED CIRCUITS AT THE LOCATIONS SHOWN FOR: Z2 AND Z4.

INSTALLATION OF RESISTORS

- () INSTALL ONE 560 OHM (GRN-BLU-BRN) 1/4 WATT RESISTOR AT THE LOCATION SHOWN ON THE ASSEMBLY DRAWING FOR R2.
- () INSTALL A 1 K OHM (BRN-BLK-RED) 1/4 WATT RESISTOR AT THE LOCATION SHOWN FOR R1. THEN INSTALL TWENTY NINE MORE 1 K OHM 1/4 WATT RESISTORS AT LOCATIONS R3 THROUGH R31.

INSTALLATION OF DIODES

- () INSTALL ONE 6.3 VOLT ZENER DIODE AT THE LOCATION SHOWN FOR VR1. BE SURE AND OBSERVE CORRECT POLARITY AS INDICATED ON THE DRAWING.

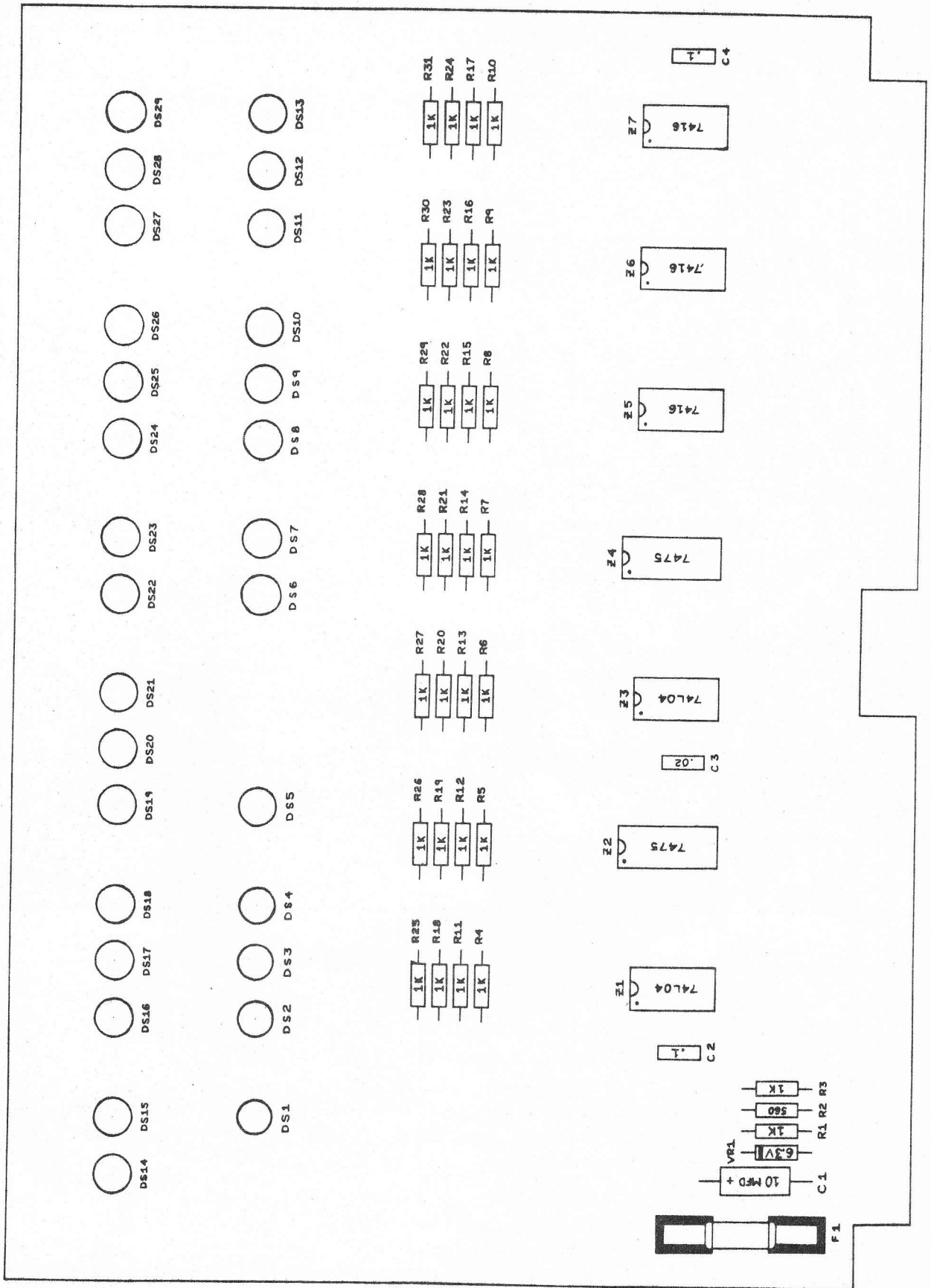

INSTALLATION OF CAPACITORS

- () INSTALL ONE 10 MFD ELECTROLYTIC CAPACITOR IN THE POSITION LABELED ON THE DRAWING FOR C1. BE CERTAIN THAT THE POSITIVE (+) END OF THE CAPACITOR IS ORIENTED IN THE SAME DIRECTION AS THAT SHOWN ON THE DRAWING AND INDICATED ON THE P.C. CARD.
- () INSTALL TWO .1 UFD DISK CAPACITORS IN THE POSITIONS LABELED ON THE DRAWING AS: C2 AND C4.
- () INSTALL ONE .02 UFD DISK CAPACITOR AT THE LOCATION IDENTIFIED ON THE ASSEMBLY DRAWING FOR C3.

INSTALLATION OF LIGHT EMITTING DIODES

- () INSTALL TWENTY NINE TYPE MV520 LIGHT EMITTING DIODES IN THE POSITIONS LABELED ON THE DRAWING FOR DS1 THROUGH DS29. THE ANODE OF THE L.E.D. (SHORTER LEAD) GOES IN THE TOP MOST HOLE (FURTHEST AWAY FROM THE CARD CONNECTOR). THE CATHODE OF THE L.E.D. (LONGER LEAD) GOES IN THE BOTTOM HOLE. PUSH THE DIODE LEADS THROUGH THE HOLE UNTIL THE WIDER PORTION OF THE LEADS ARE FLUSH WITH THE BOARD. THEN TURN THE CARD OVER, SOLDER THE LEADS TO THE FOIL, AND TRIM OFF THE EXCESS LEAD.

INSTALLATION OF FUSE CLIPS

- () INSTALL THE TWO P.C. MOUNTING FUSE CLIPS IN THE POSITIONS SHOWN TO HOLD FUSE F1. INSERT THE TWO TABS ON THE BASE OF EACH CLIP INTO THE HOLES PROVIDED, BEND THE TABS SLIGHTLY AGAINST THE FOIL ON THE OTHER SIDE OF THE CARD TO HOLD THEM IN PLACE AND THEN SOLDER EACH TAB TO THE FOIL. ENSURE THAT THE CLIPS LINE UP SO THAT A FUSE WILL SEAT PROPERLY WHEN INSTALLED.

INITIAL INSPECTION AND TESTING

- () AT THIS TIME CAREFULLY INSPECT BOTH SIDES OF THE CARD TO ASCERTAIN THAT THERE ARE NO SOLDER SHORTS BETWEEN P.C. FOIL LANDS. BE ESPECIALLY OBSERVANT ON THE COMPONENT SIDE OF THE CARD AROUND THE I.C. PINS. REMOVE ANY SOLDER SHORTS THAT ARE FOUND.

- () INSTALL A 3/8 AMPERE TYPE 8AG FUSE IN THE FUSE CLIPS FOR F1.

- () USE AN OHM METER TO MAKE THE FOLLOWING MEASUREMENTS:

METER BETWEEN PINS A1 AND 3 OF THE CARD CONNECTOR - AND THEN REVERSE THE METER LEADS TO OBTAIN A SECOND READING. THE READING IN BOTH DIRECTIONS SHOULD BE GREATER THAN FIVE (5) OHMS. (ONE READING WILL TYPICALLY BE SEVERAL TIMES HIGHER THAN THE OTHER.) IF THE READINGS ARE LESS THAN FIVE OHMS LOOK FOR SOLDER SHORTS BETWEEN THE +5 VOLT SUPPLY LINES AND THE COMMON RETURN LINES ON THE CARD.

NOW REPEAT THE ABOVE READINGS BETWEEN PINS A3 AND A5 OF THE CARD CONNECTOR. THIS TIME THE READINGS IN BOTH DIRECTIONS SHOULD BE

GREATER THAN 50 OHMS. IF THIS IS NOT THE CASE, LOOK FOR SOLDER SHORTS BETWEEN THE -9 VOLT SUPPLY LINES AND THE COMMON RETURN LINES ON THE CARD.

FINALLY, TAKE SIMILAR READINGS BETWEEN PINS A1 AND A5 OF THE CARD CONNECTOR. AGAIN THE READINGS IN BOTH DIRECTIONS SHOULD BE GREATER THAN 50 OHMS. IF NOT, LOOK FOR SOLDER SHORTS BETWEEN THE +5 VOLT AND -9 VOLT SUPPLY LINES ON THE P.C. CARD.

FINAL TESTING

FINAL TESTING OF THE CARD MUST BE ACCOMPLISHED WHEN THE CARD IS INSTALLED IN A SCELBI-8B MINICOMPUTER CHASSIS UNIT.

SCELBI COMPUTER CONSULTING, INC.

ASSEMBLY INSTRUCTIONS - SCELBI CARD #: 1106-

MEMORY EXPANSION CARD

DESCRIPTION

THE SCELBI #1106 MEMORY EXPANSION CARD CONTAINS MEMORY ADDRESS LOGIC WHICH ENABLES THE COMPUTER TO SELECT THE DESIRED "PAGE" OF MEMORY IN A SYSTEM THAT MAY CONTAIN "PAGES" OR "BANKS" OF MEMORY ELEMENTS.

KIT ASSEMBLY

YOU SHOULD REFER TO THE ASSEMBLY DRAWING SHOWN ON THE NEXT PAGE DURING THE ASSEMBLY PROCESS. THE DRAWING IS TO SCALE AND SHOWS THE EXACT LOCATION OF EACH PART ON THE P.C. CARD.

INSTALLATION OF INTEGRATED CIRCUITS

- () INSTALL NINE TYPE 7442 INTEGRATED CIRCUITS IN THE LOCATIONS LABELED ON THE ASSEMBLY DRAWING AS: Z1 - Z7, Z9 & Z10. WHEN ALL NINE HAVE BEEN INSTALLED TURN THE CARD OVER AND SOLDER THE PINS ON EACH I.C. TO THEIR FOIL PAD.
- () INSTALL A TYPE 7417 I.C. AT THE LOCATION SPECIFIED FOR Z8 ON THE ASSEMBLY DRAWING. SOLDER THE PINS OF THE INTEGRATED CIRCUIT TO THE CARD.

INSTALLATION OF RESISTORS

- () INSTALL 67 10 K OHM (BRN-BLK-OR) 1/4 WATT RESISTORS AT THE LOCATIONS SHOWN ON THE ASSEMBLY DRAWING FOR: R1 - R67.

INSTALLATION OF DIODES

- () INSTALL ONE 6.3 VOLT ZENER DIODE AT THE LOCATION SHOWN FOR VR1. BE SURE AND OBSERVE CORRECT POLARITY AS INDICATED ON THE DRAWING.

INSTALLATION OF CAPACITORS

- () INSTALL ONE 10 MFD ELECTROLYTIC CAPACITOR IN THE POSITION LABELED ON THE DRAWING FOR C1. BE CERTAIN THAT THE POSITIVE (+) END OF THE CAPACITOR IS ORIENTED IN THE SAME DIRECTION AS THAT SHOWN ON THE DRAWING AND INDICATED ON THE P.C. CARD.
- () INSTALL THREE .1 UFD DISK CAPACITORS IN THE POSITIONS LABELED ON THE DRAWING AS: C2, C3 & C4.

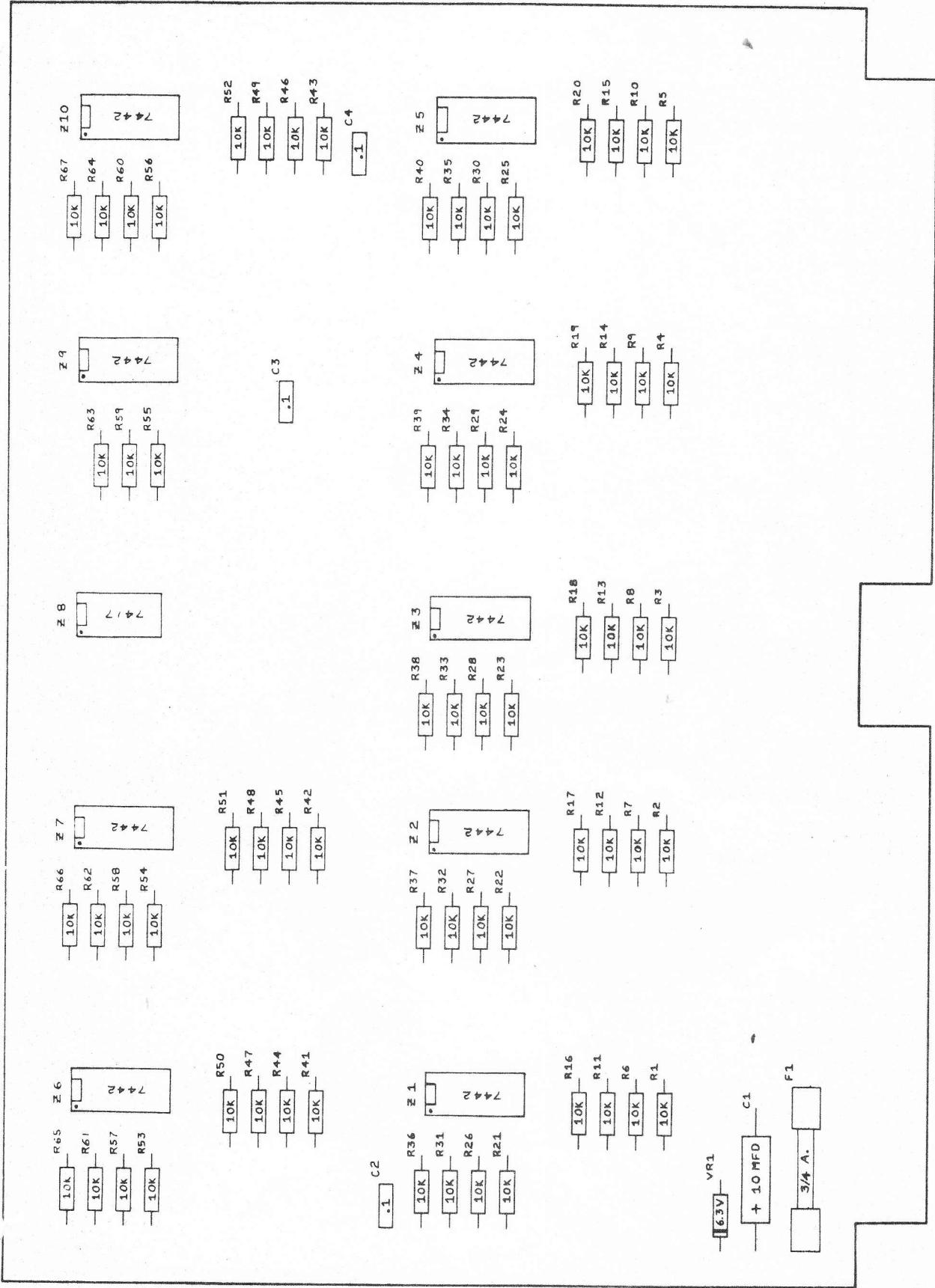

1106 - MEM EXP

INSTALLATION OF FUSE CLIPS

- () INSTALL THE TWO P.C. MOUNTING FUSE CLIPS IN THE POSITIONS SHOWN TO HOLD FUSE F1. INSERT THE TWO TABS ON THE BASE OF EACH CLIP INTO THE HOLES PROVIDED. BEND THE TABS SLIGHTLY AGAINST THE FOIL ON THE OTHER SIDE OF THE CARD TO HOLD THEM IN PLACE AND THEN SOLDER EACH TAB TO THE FOIL. ENSURE THAT THE CLIPS LINE UP SO THAT A FUSE WILL SEAT PROPERLY WHEN INSTALLED.

INITIAL INSPECTION AND TESTING

- () AT THIS TIME CAREFULLY INSPECT BOTH SIDES OF THE CARD TO ASCERTAIN THAT THERE ARE NO SOLDER SHORTS BETWEEN P.C. FOIL LANDS. BE ESPECIALLY OBSERVANT ON THE COMPONENT SIDE OF THE CARD AROUND THE I.C. PINS. REMOVE ANY SOLDER SHORTS THAT ARE FOUND.

- () INSTALL A 3/8 AMPERE TYPE 6AG FUSE IN THE FUSE CLIPS FOR F1.

- () USE AN OHM METER TO MAKE THE FOLLOWING MEASUREMENTS:

METER BETWEEN PINS A1 AND A3 OF THE CARD CONNECTOR - AND THEN REVERSE THE METER LEADS TO OBTAIN A SECOND READING. THE READING IN BOTH DIRECTIONS SHOULD BE GREATER THAN FIVE (5) OHMS. (ONE READING WILL BE TYPICALLY SEVERAL TIMES HIGHER THAN THE OTHER.) IF THE READING(S) ARE LESS THAN FIVE OHMS LOOK FOR SOLDER SHORTS BETWEEN THE +5 VOLT SUPPLY LINES AND THE COMMON RETURN LINES ON THE CARD.

FINAL TESTING

FINAL TESTING OF THE CARD MUST BE ACCOMPLISHED WHEN THE CARD IS INSTALLED IN A SCELBI-8B MINICOMPUTER CHASSIS UNIT.

SCELBI COMPUTER CONSULTING, INC.

ASSEMBLY INSTRUCTIONS - SCELBI CARD #: 1107-

4K RAM MEMORY CARD

DESCRIPTION

THE SCELBI #1107 RAM MEMORY CARD MAY BE POPULATED WITH TYPE 2102 (STATIC RAM) MEMORY ELEMENTS IN GROUPS OF 1,024 WORDS TO A MAXIMUM OF 4,096 WORDS PER CARD. THE CARD ALSO CONTAINS MEMORY BANK SELECTION LOGIC. THESE CARDS SERVE AS THE "READ AND WRITE" MEMORY BANK(S) FOR A SCELBI-8B SYSTEM. THE STANDARD SCELBI-8B CHASSIS HAS P.C. CARD SOCKETS TO ACCEPT UP TO FOUR OF THESE CARDS ALLOWING FOR UP TO 16,384 WORDS OF MEMORY TO BE USED BY THE COMPUTER.

KIT ASSEMBLY

YOU SHOULD REFER TO THE ASSEMBLY DRAWING SHOWN ON THE NEXT PAGE DURING THE ASSEMBLY PROCESS. THE DRAWING IS TO SCALE AND SHOWS THE EXACT LOCATION OF EACH PART ON THE P.C. CARD.

INSTALLATION OF INTEGRATED CIRCUITS

NOTICE: THE FOLLOWING FOUR STEPS DETAIL THE INSTALLATION OF THE RAM MEMORY INTEGRATED CIRCUITS FOR AN 1107- CARD SUPPLIED WITH 4,096 WORDS OF MEMORY (32 MEMORY CHIPS). IF YOU PURCHASED A BOARD WITH LESS MEMORY, THEN PERFORM THE STEPS IN ORDER FOR EACH GROUP OF EIGHT MEMORY CHIPS PROVIDED.

- () INSTALL EIGHT TYPE 2102 INTEGRATED CIRCUITS IN THE LOCATIONS LABELED ON THE DRAWING AS Z29 - Z36. WHEN ALL EIGHT HAVE BEEN INSTALLED TURN THE CARD OVER AND SOLDER THE PINS ON EACH I.C. TO THEIR FOIL PAD. (THIS PROVIDES FOUR PAGES OF MEMORY ON THE FOUR LOWEST VALUED SELECT LINES FOR THE CARD.)
- () INSTALL EIGHT TYPE 2102 INTEGRATED CIRCUITS IN THE LOCATIONS LABELED ON THE DRAWING AS Z21 - Z28. (THIS PROVIDES FOUR PAGES OF MEMORY ON THE NEXT HIGHER ORDER SELECT LINES FOR THE CARD.)
- () INSTALL EIGHT TYPE 2102 INTEGRATED CIRCUITS IN THE LOCATIONS LABELED ON THE DRAWING AS Z11 - Z18. (THIS PROVIDES FOUR PAGES OF MEMORY ON THE NEXT HIGHER ORDER SELECT LINES FOR THE CARD.)
- () INSTALL EIGHT TYPE 2102 INTEGRATED CIRCUITS IN THE LOCATIONS LABELED ON THE DRAWING AS Z1 - Z8. (THIS PROVIDES FOUR PAGES OF MEMORY ON THE FOUR HIGHEST VALUED SELECT LINES FOR THE CARD.)
- () INSTALL TWO TYPE 7400 INTEGRATED CIRCUITS IN THE LOCATIONS LABELED ON THE ASSEMBLY DRAWING AS: Z19 AND Z20.
- () INSTALL TWO TYPE 7420 INTEGRATED CIRCUITS IN THE LOCATIONS LABELED ON THE ASSEMBLY DRAWING AS: Z9 AND Z10.
- () INSTALL A TYPE 7404 INTEGRATED CIRCUIT IN THE LOCATION LABELED ON THE ASSEMBLY DRAWING AS: Z37.

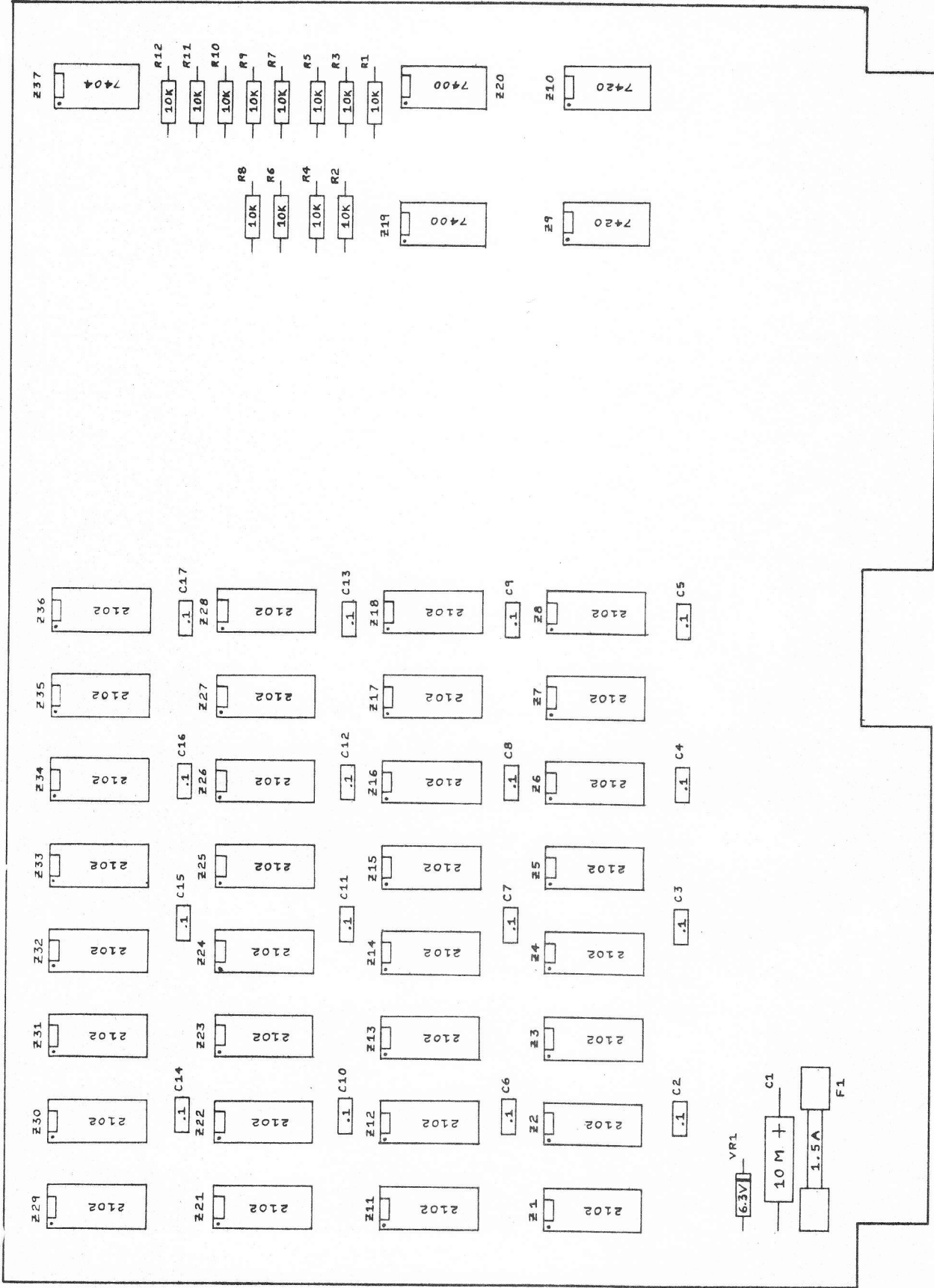

1107 - 4K RAM

INSTALLATION OF RESISTORS

- () INSTALL TWELVE 10 K OHM (BRN-BLK-OR) 1/4 WATT RESISTORS AT THE LOCATIONS SHOWN ON THE ASSEMBLY DRAWING FOR: R1 - R12.

INSTALLATION OF DIODES

- () INSTALL ONE 6.3 VOLT ZENER DIODE AT THE LOCATION SHOWN FOR VR1. BE SURE AND OBSERVE CORRECT POLARITY AS INDICATED ON THE DRAWING.

INSTALLATION OF CAPACITORS

- () INSTALL ONE 10 MFD ELECTROLYTIC CAPACITOR IN THE POSITION LABELED ON THE DRAWING FOR C1. BE CERTAIN THAT THE POSITIVE (+) END OF THE CAPACITOR IS ORIENTED IN THE SAME DIRECTION AS THAT SHOWN ON THE DRAWING AND INDICATED ON THE P.C. CARD.
- () INSTALL SIXTEEN .1 UFD DISK CAPACITORS IN THE POSITIONS LABELED ON THE DRAWING AS: C2 - C17.

INSTALLATION OF FUSE CLIPS

- () INSTALL THE TWO P.C. MOUNTING FUSE CLIPS IN THE POSITIONS SHOWN TO HOLD FUSE F1. ENSURE THAT THE CLIPS LINE UP SO THAT A FUSE WILL SEAT PROPERLY WHEN INSTALLED.

INITIAL INSPECTION AND TESTING

- () AT THIS TIME CAREFULLY INSPECT BOTH SIDES OF THE CARD TO ASCERTAIN THAT THERE ARE NO SOLDER SHORTS BETWEEN P.C. FOIL LANDS. BE ESPECIALLY OBSERVANT ON THE COMPONENT SIDE OF THE CARD AROUND THE I.C. PINS. REMOVE ANY SOLDER SHORTS THAT ARE FOUND.
- () INSTALL A 1.5 AMPERE TYPE 8AG FUSE IN THE FUSE CLIPS FOR F1.
- () USE AN OHM METER TO MAKE THE FOLLOWING MEASUREMENTS:

METER BETWEEN PINS A1 AND A3 OF THE CARD CONNECTOR - AND THEN REVERSE THE METER LEADS TO OBTAIN A SECOND READING. THE READING IN BOTH DIRECTIONS SHOULD BE GREATER THAN FIVE (5) OHMS. (ONE READING WILL BE TYPICALLY SEVERAL TIMES HIGHER THAN THE OTHER.) IF THE READING(S) ARE LESS THAN FIVE OHMS LOOK FOR SOLDER SHORTS BETWEEN THE +5 VOLT SUPPLY LINES AND THE COMMON RETURN LINES ON THE CARD.

FINAL TESTING

FINAL TESTING OF THE CARD MUST BE ACCOMPLISHED WHEN THE CARD IS INSTALLED IN A SCELBI-8B MINICOMPUTER CHASSIS UNIT.

SCELBI COMPUTER CONSULTING, INC.

ASSEMBLY INSTRUCTIONS - SCELBI CARD #: 1109-

ROM/PROM MEMORY CARD

DESCRIPTION

THE SCELBI #1109 ROM/PROM MEMORY CARD IS AN OPTIONAL CARD. THE CARD MAY BE POPULATED WITH UP TO 16 TYPE 1602 OR 1702 PROMS. AT 256 WORDS PER ROM THIS ALLOWS UP TO 4,096 WORDS OF ROM MEMORY TO BE STORED ON EACH CARD. THE CARD MAY BE PLUGGED INTO ANY MEMORY CARD SLOT IN A SCELBI-8B SYSTEM TO SUBSTITUTE ROM/PROM MEMORY FOR RAM MEMORY.

KIT ASSEMBLY

YOU SHOULD REFER TO THE ASSEMBLY DRAWING SHOWN ON THE NEXT PAGE DURING THE ASSEMBLY PROCESS. THE DRAWING IS TO SCALE AND SHOWS THE EXACT LOCATION OF EACH PART ON THE P.C. CARD.

INSTALLATION OF DIODES

- () INSTALL ONE 6.3 VOLT ZENER DIODE AT THE LOCATION SHOWN FOR VR1. BE SURE AND OBSERVE CORRECT POLARITY AS INDICATED ON THE DRAWING.
- () INSTALL ONE 12.0 VOLT ZENER DIODE AT THE LOCATION SHOWN FOR VR2. BE SURE AND OBSERVE CORRECT POLARITY AS INDICATED ON THE DRAWING.

INSTALLATION OF CAPACITORS

- () INSTALL ONE 10 MFD ELECTROLYTIC CAPACITOR IN THE POSITION LABELED ON THE DRAWING FOR C1. BE CERTAIN THAT THE POSITIVE (+) END OF THE CAPACITOR IS ORIENTED IN THE SAME DIRECTION AS THAT SHOWN ON THE DRAWING AND INDICATED ON THE P.C. CARD.
- () INSTALL FOUR .1 UFD DISK CAPACITORS IN THE POSITIONS LABELED ON THE DRAWING AS: C3, C5, C7 AND C9.
- () INSTALL FOUR .02 UFD DISK CAPACITORS IN THE POSITIONS LABELED ON THE DRAWING AS: C2, C4, C6 AND C8.

INSTALLATION OF FUSE CLIPS

- () INSTALL THE FOUR P.C. MOUNTING FUSE CLIPS IN THE POSITIONS SHOWN TO HOLD FUSES F1 AND F2. ENSURE THAT THE CLIPS LINE UP SO THAT A FUSE WILL SEAT PROPERLY WHEN INSTALLED.
- () INSTALL TWO 1.5 AMPERE TYPE 8AG FUSES IN THE FUSE CLIPS FOR F1 AND F2.

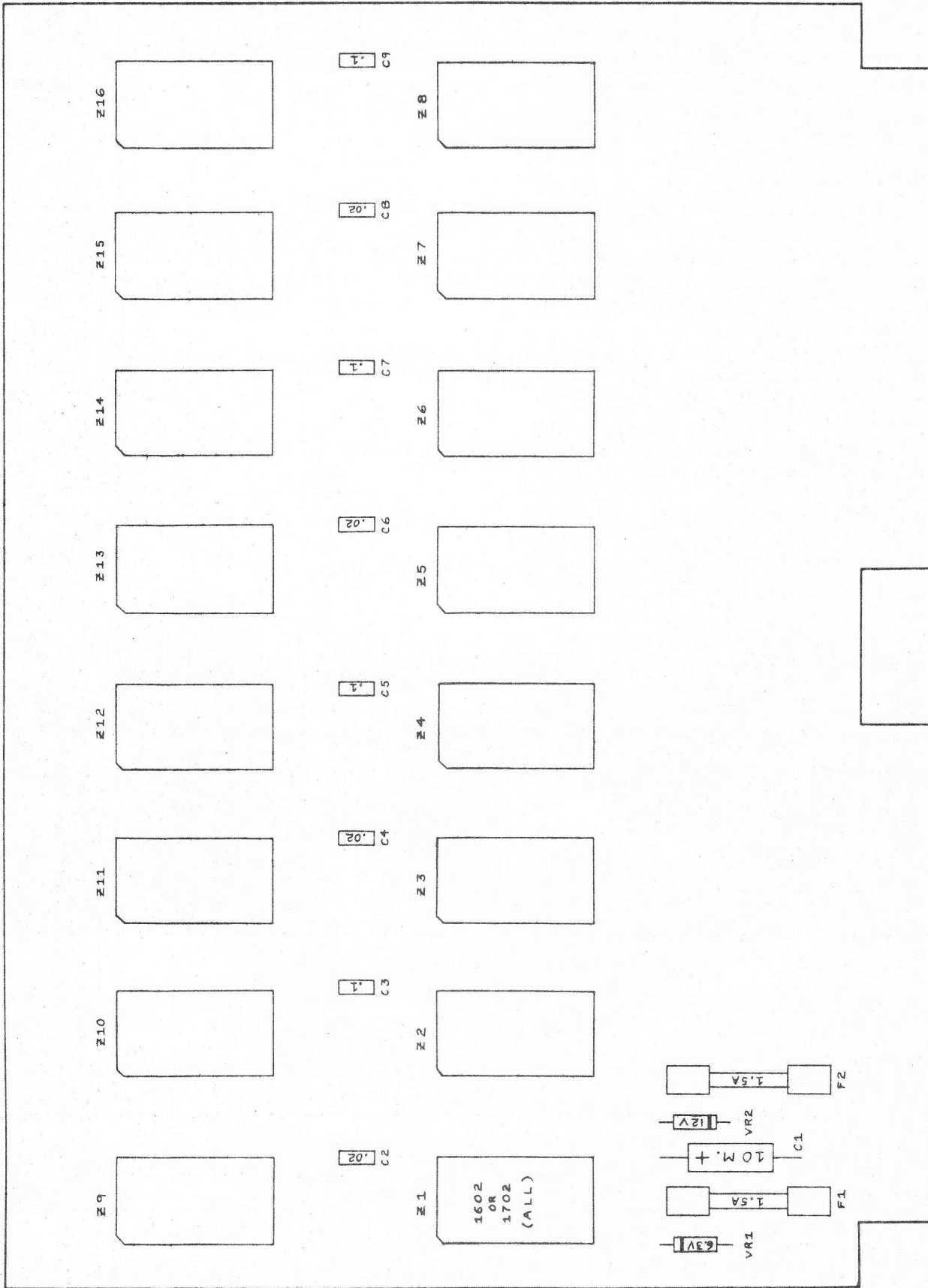

1109 - PROM

INSTALLATION OF ROMS/PROMS

IT IS RECOMMENDED THAT SOCKETS BE INSTALLED ON THE CARD AND THE ROMS OR PROMS THEN INSTALLED IN THE SOCKETS. THE ROM/PROM POSITIONS ON THE CARD ARE DESIGNATED AS Z1 THROUGH Z16. EACH ROM/PROM POSITION CORRESPONDS TO A "PAGE" IN MEMORY - WITH Z1 BEING THE POSITION FOR THE LOWEST "PAGE" ADDRESS ON THE CARD AND Z16 BEING THE POSITION FOR THE HIGHEST PAGE ADDRESS ON THE CARD. WHEN A ROM/PROM IS TO BE INSTALLED, SELECT THE CORRECT POSITION ON THE CARD FOR THE "PAGE" ADDRESS IN MEMORY FOR WHICH THE PROGRAM ON THE PROM IS DESIGNED TO OPERATE. INSTALL A 24 PIN INTEGRATED CIRCUIT SOCKET ON THE CARD AND SOLDER THE SOCKET PINS. THEN INSTALL THE ROM/PROM.

AS AN EXAMPLE, IF IT WERE DESIRED TO INSTALL A ROM WITH A PROGRAM ON IT DESIGNED TO OPERATE WHEN ADDRESSED AS PAGE 67 IN A SCELBI-8B SYSTEM, THE ROM WOULD BE INSTALLED AT LOCATION Z7 ON THE CARD. THE CARD WOULD THEN BE INSTALLED IN THE LAST MEMORY CARD SLOT (XA9) ON A SCELBI-8B CHASSIS UNIT.

APPENDIX - INITIAL P.C. CARD TESTING

EXPERIENCE HAS INDICATED THAT THE MAJORITY OF PROBLEMS FOUND WITH P.C. CARDS THAT HAVE BEEN ASSEMBLED BY THE PURCHASER FALL INTO SEVERAL MAJOR CATEGORIES.

1. SOLDER SHORTS BETWEEN P.C. FOIL LANDS.
2. COMPONENTS INSTALLED INCORRECTLY OR IN THE WRONG LOCATION.
3. OCCASIONALLY A MINOR DEFECT IN A P.C. CARD - SUCH AS AN OPEN OR SHORTED P.C. FOIL LAND WILL OCCUR. SCELBI CAREFULLY INSPECTS P.C. CARDS BUT THE FINAL TEST OF A P.C. CARDS FOIL INTEGRITY CAN ONLY BE MADE WHEN THE CARD IS PUT INTO OPERATION.
4. VERY RARELY A "FEED-THROUGH" HOLE ON A P.C. CARD WILL BE FOUND TO BE "OPEN" IN THAT THE HOLE DOES NOT CONDUCT FROM ONE SIDE OF THE BOARD TO THE OTHER.
5. BY FAR THE MOST COMMON FAULT FOUND ON CARDS WHERE PEOPLE HAVE SUPPLIED THEIR OWN PARTS IS SIMPLY DEFECTIVE COMPONENTS.

PROBLEMS FALLING INTO CATEGORIES 1, 2 AND 3 CAN OFTEN BE DETECTED AND ELIMINATED BY VERY CAREFUL VISUAL INSPECTION OF THE P.C. BOARD, BOTH DURING THE ASSEMBLY PROCESS, AND WHEN THE ASSEMBLY HAS BEEN COMPLETED. SOLDER SHORTS ARE EASILY REMOVED WITH A HOT SOLDERING IRON. SHORTED P.C. FOIL LANDS CAN BE SEPARATED BY A SHARP KNIFE. AN OPEN P.C. FOIL LAND CAN BE READILY JUMPERED WITH A PIECE OF WIRE AND A BIT OF SOLDER.

IMPROPERLY INSTALLED COMPONENTS SHOULD HAVE THEIR LEADS CUT OFF AND THEN THE REMAINING PIECE OF EACH LEAD SUCKED OUT OF THE HOLE WITH A "SOLDER SUCKER" INSTRUMENT. DO NOT TRY TO REMOVE WHOLE COMPONENTS IN ORDER TO "SAVE" THE COMPONENT AS TO ATTEMPT TO DO SO WILL OFTEN RESULT IN PERMANENT DESTRUCTION TO THE P.C. FOIL ON THE CARD. THE P.C. CARDS HAVE "PLATED-THROUGH" HOLES FOR COMPONENT LEADS - THESE HOLES BECOME FILLED WITH SOLDER WHEN THE COMPONENT IS INITIALLY SOLDERED TO THE BOARD AND IT IS EXTREMELY DIFFICULT TO TRY TO REMOVE A GROUP OF LEADS, SUCH AS THOSE ON AN INTEGRATED CIRCUIT, AT ONE TIME, WITHOUT ALSO CAUSING DAMAGE TO THE P.C. CARD.

THE 4TH CATEGORY LISTED ABOVE IS NOT READILY DETECTED BY VISUAL INSPECTION. THIS PROBLEM IS RARE IN SCELBI P.C. CARDS BUT IT CAN OCCUR. THE DETECTION IS GENERALLY EASY ONCE A PROBLEM HAS BEEN LOCALIZED TO A PARTICULAR CIRCUIT IN THAT A DRIVING SIGNAL PRESENT AT AN OUTPUT DEVICE WILL NOT BE PRESENT AT THE INPUT DEVICE(S) IT IS SUPPOSED TO DRIVE. AN OHM METER CHECK WILL VERIFY AN OPEN FEED THROUGH. AN OPEN FEED THROUGH HOLE CAN BE FIXED BY INSERTING A PIECE OF WIRE THROUGH THE HOLE AND SOLDERING IT IN PLACE.

LOCATING FAULTY COMPONENTS GENERALLY REQUIRES SOME TECHNICAL SKILL SUCH AS THE ABILITY TO FOLLOW THE LOGIC DETAILED IN THE SCHEMATICS WHICH ARE INCLUDED IN THE TECHNICAL SECTION AT THE END OF THIS CHAPTER. AN OSCILLOSCOPE OR OTHER SUITABLE LOGIC INDICATING PROBE IS GENERALLY REQUIRED. USER'S WHO APPEAR TO HAVE FAULTY COMPONENTS SHOULD TAKE APPROPRIATE STEPS TO LOCATE THE FAULTY COMPONENT BY REFERRING TO THE TECHNICAL SECTION. (THOSE THAT DO NOT HAVE THE NECESSARY SKILLS AND/OR EQUIPMENT MAY RETURN THEIR UNITS FOR TESTING/REPAIR. SUCH SERVICES ARE FREE IF THE CUSTOMER'S WARRANTY APPLIES. A MODEST SERVICE CHARGE APPLIES IN ALL OTHER CASES. BE SURE TO OBTAIN A RETURN AUTHORIZATION FROM THE FACTORY IF IT IS NECESSARY TO RETURN A UNIT!)

INTRODUCTION

THIS SECTION PROVIDES ASSEMBLY AND INSTALLATION INSTRUCTIONS FOR THE CHASSIS PORTION OF THE SCALBI-8B MINICOMPUTER. IT CONSIST OF THREE MAIN SECTIONS.

1. SCALBI-8B CARD SOCKET INTER-CONNECTION WIRING.
2. WIRING TO INPUT/OUTPUT CONNECTORS.
3. SCALBI-8B CARD SET INSTALLATION AND CHECK OUT.

CUSTOMERS WHO PURCHASED COMPLETELY ASSEMBLED AND TESTED SCALBI-8B MINICOMPUTERS MAY PROCEED DIRECTLY TO THE THIRD PART OF THIS SECTION. SECTIONS 1 AND 2 SERVE AS REFERENCES FOR THOSE CUSTOMERS AS THE INFORMATION DETAILED THEREIN HAS BEEN PERFORMED AT THE FACTORY.

CUSTOMERS WHO PURCHASED SCALBI-8B CHASSIS KITS SHOULD START AT SECTION TWO. THE WIRING DISCUSSED IN SECTION 1 IS CONTAINED ON THE SCALBI-8B BACKPLANE HARNESS BOARD AND/OR WAS COMPLETED AT THE FACTORY.

CUSTOMERS WHO PURCHASED JUST A SCALBI-8B CARD SET AND WHO ARE PROVIDING THEIR OWN CHASSIS AND CARD MOUNTING HARDWARE SHOULD START WITH SECTION ONE.

SECTION I

CUSTOMERS WHO PURCHASE JUST THE BASIC CARD SET FOR THE SCALBI-8B MINICOMPUTER HAVE TO PROVIDE THEIR OWN CHASSIS, CARD CONNECTORS, I/O CONNECTORS AND CHASSIS CONSOLE SWITCHES. THEY MUST THEN INTER-CONNECT THESE COMPONENTS TO PROVIDE THEIR OPERATING COMPUTER. SINCE INDIVIDUAL TASTES WILL DICTATE THE TYPE OF MECHANICAL CONFIGURATION FOR SUCH SYSTEMS, THE FOLLOWING INFORMATION WILL BE DEVOTED TO THE WIRING REQUIRED TO CONNECT THE SCALBI-8B CARDS INTO AN OPERATING COMPUTER. AS AN AID TO PRESENTING THE INFORMATION, IT WILL BE ASSUMED THAT THE CARDS ARE TO BE ARRANGED IN THE SAME ORDER AS THEY APPEAR ON A STANDARD FACTORY ASSEMBLED SCALBI-8B.

THE READER SHOULD REFER TO THE CHASSIS DRAWINGS PRESENTED ON THE NEXT TWO PAGES. ONE, SHOWING A TOP VIEW OF A SCALBI-8B MINICOMPUTER, ILLUSTRATES THE ORDER IN WHICH CARDS ARE ARRANGED. THE SECOND PRESENTS A BOTTOM VIEW OF A CHASSIS TO ILLUSTRATE CONNECTION POINTS FROM CARD SOCKETS TO I/O CONNECTORS AND SWITCHES. IF A BUILDER DESIRES TO APPROXIMATE A SCALBI-8B CHASSIS UNIT THE FOLLOWING INFORMATION WILL BE USEFUL. A 10 X 12 X 3 INCH ALUMINUM CHASSIS CAN SERVE AS A BASE UNIT. PAIRS OF 44 PIN CARD CONNECTORS, SUCH AS AMPHENOL #22221-404 UNITS, CAN BE LAID OUT ALONG THE TOP OF THE CHASSIS IN PAIRS TO ACCEPT THE CARD EDGE FINGERS ON THE SCALBI-8B P.C. CARDS. THE DISTANCE BETWEEN PAIRS OF CARD SOCKETS SHOULD BE 3/4 INCH OR MORE TO PROVIDE SUFFICIENT ROOM FOR PROPER AIR FLOW AND HEAT DISSIPATION BETWEEN CARDS.

FOR WIRING PURPOSES, CARD SOCKETS WHEN ARRANGED AS ILLUSTRATED IN

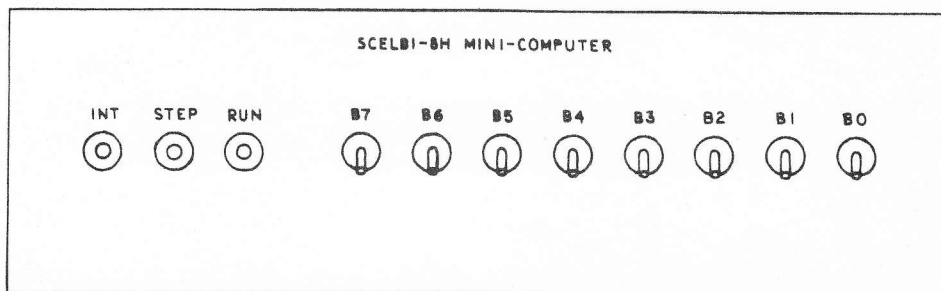
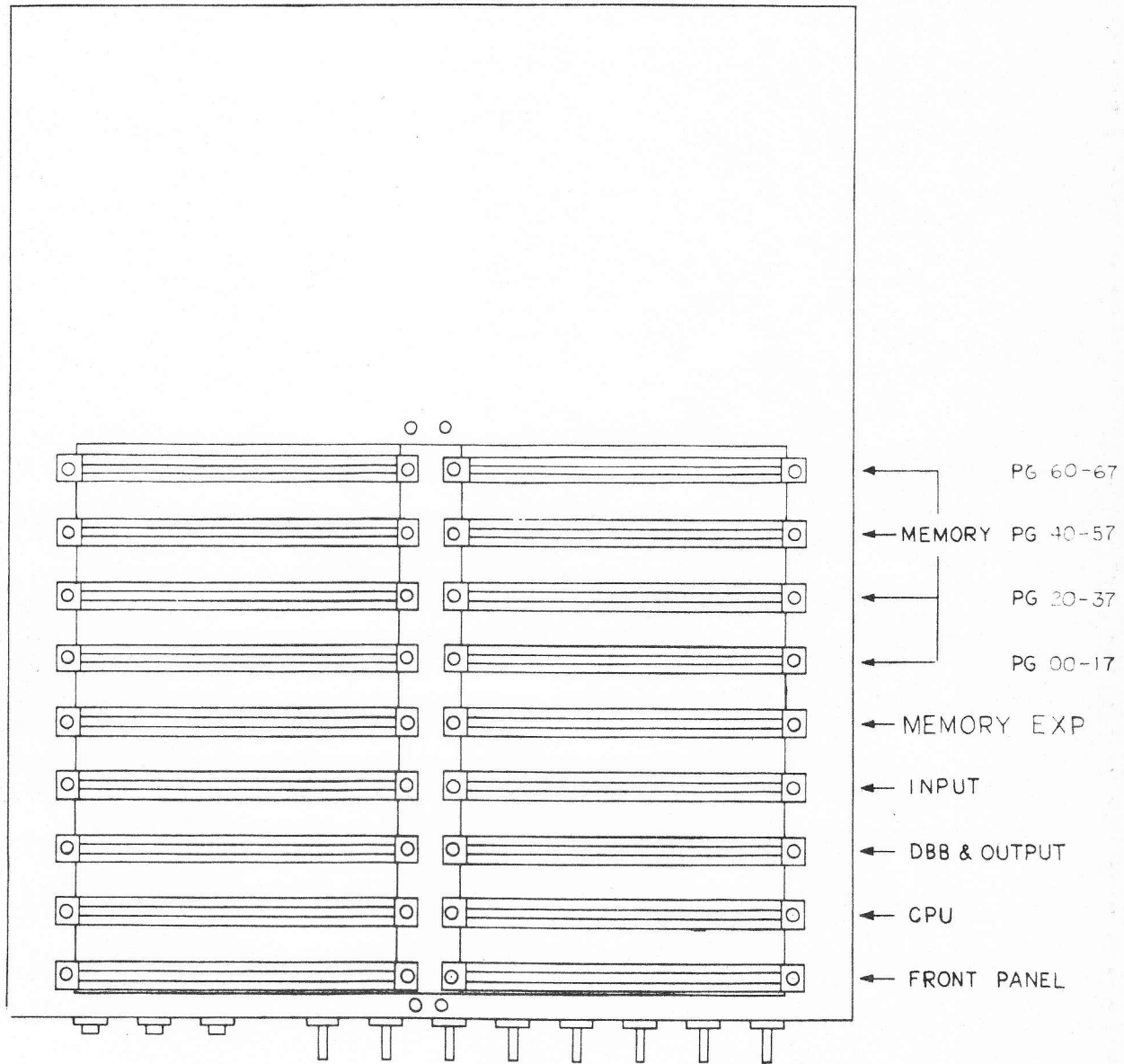
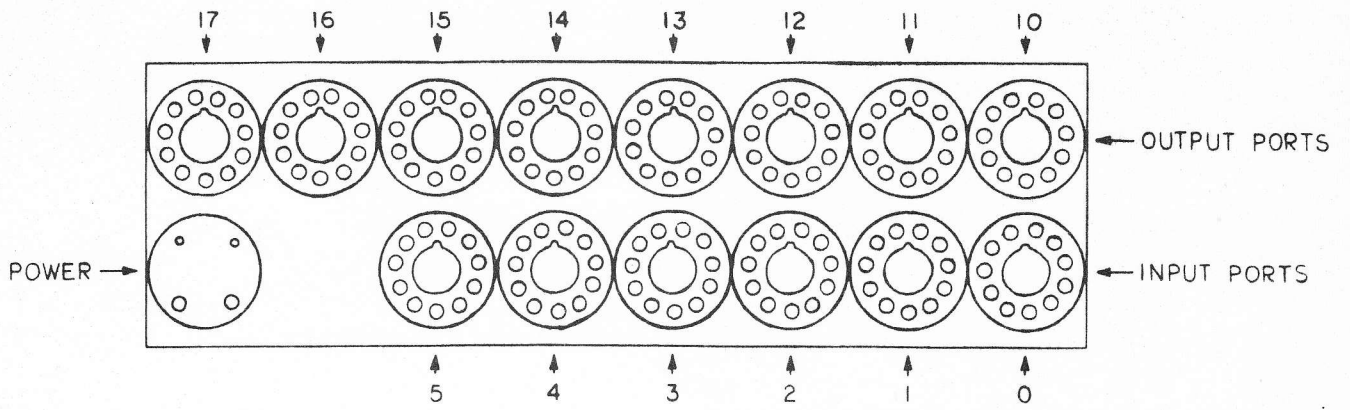

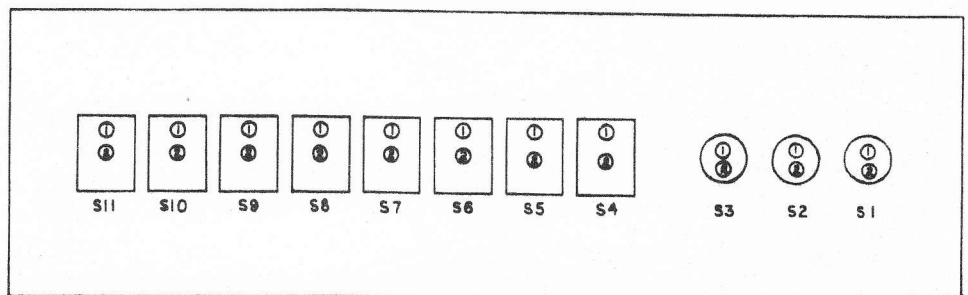
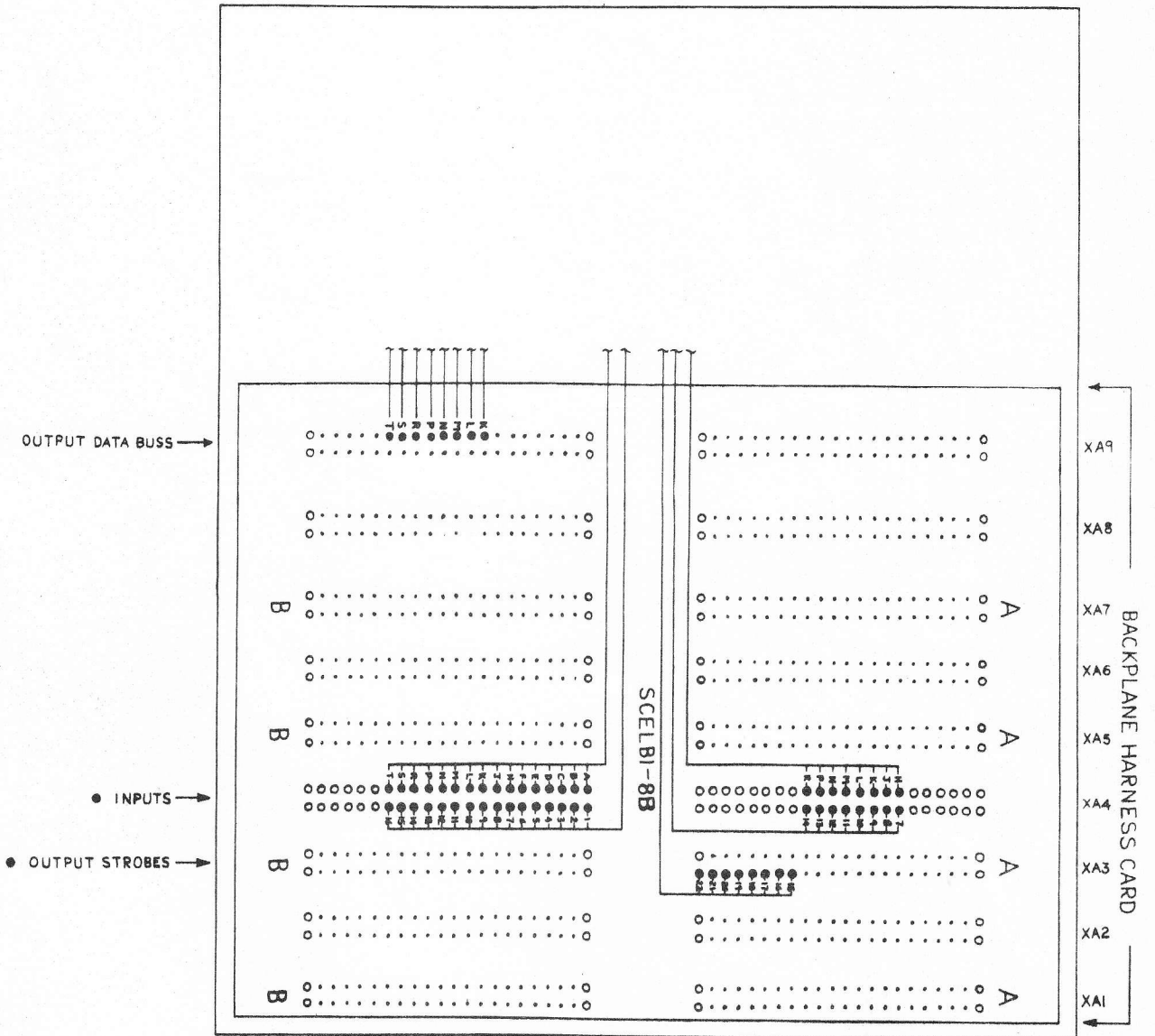
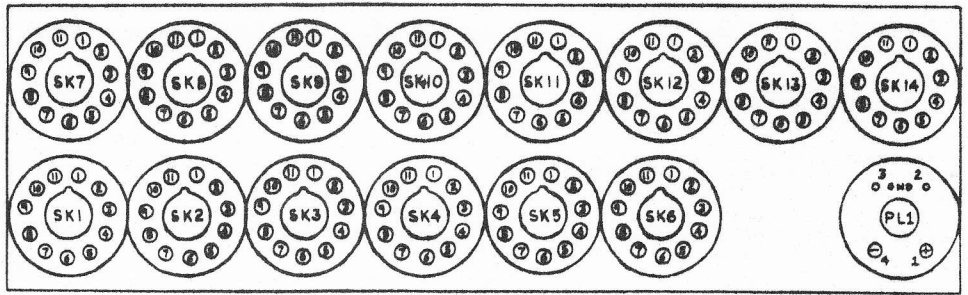

THE PREVIOUS DRAWINGS, HAVE BEEN GIVEN THE FOLLOWING REFERENCE DESIGNATIONS. FIRST, CARD SLOTS FROM FRONT TO BACK, ARE REFERED TO BY "XA" NUMBER. THE FRONT MOST SLOT IS XA01, AND IN A STANDARD SYSTEM THE LAST SLOT IS DESIGNATED XA09. SINCE EACH SLOT CONTAINS TWO CARD SOCKETS THE LEFT MOST SOCKET (WHEN VIEWED FROM THE FRONT OF THE UNIT) IS TERMED THE "A" SOCKET AND THE RIGHT ONE DESIGNATED THE "B" SOCKET. FINALLY, THE PINS ON EACH SOCKET ARE DESIGNATED AS FOLLOWS. THE ROW OF 22 PINS THAT ARE TOWARDS THE FRONT OF THE UNIT ARE DESIGNATED FROM LEFT TO RIGHT (AGAIN, AS VIEWED FROM THE FRONT) AS PINS NUMBERS 1 THROUGH 22. THE OTHER ROW OF 22 PINS ARE REFERRED TO BY ALPHABETICAL DESIGNATIONS USING THE LETTERS A THROUGH Z WITH THE LETTERS G, I, O AND Q OMITTED. IT IS IMPORTANT TO ENSURE THAT THE UNIT BEING CONSTRUCTED FOLLOWS THESE REFERENCE DESIGNATIONS SO THAT THE UNIT IS WIRED PROPERLY. ALL REFERENCES IN THIS SECTION RELATE TO THE ABOVE LABELING CONVENTION.

I/O SOCKETS, AND THE POWER PLUG MAY BE MOUNTED ALONG THE REAR OF THE CHASSIS UNIT AS ILLUSTRATED. THE STANDARD SCELBI-8B I/O CONNECTOR IS AN 11 PIN AMPHENOL TYPE 78S11 SOCKET MOUNTED WITH THE "KEY" POINTING TOWARDS THE BOTTOM OF THE CHASSIS. STANDARD SCELBI PERIPHERAL CABLES MATE WITH THIS TYPE OF SOCKET. IF YOU DESIRE TO USE ANOTHER TYPE OF I/O CONNECTOR YOU WILL HAVE TO PREPARE YOUR OWN I/O CABLES AND YOU WILL HAVE TO ARRANGE YOUR OWN PIN ASSIGNMENTS AND APPROPRIATELY ALTER THE I/O WIRING DESIGNATIONS PROVIDED IN THE NEXT SECTION.

THE POWER PLUG ON A STANDARD SCELBI UNIT IS AN AMPHENOL TYPE 86CP4 OR EQUIVALENT. THIS IS A FOUR PIN "KEYED" MALE PLUG USED FOR BRINGING IN OPERATING POWER TO THE COMPUTER CARD SET AS SHOWN IN THE DRAWINGS.

THERE ARE ELEVEN SWITCHES NECESSARY FOR OPERATING THE SCELBI-8B MINICOMPUTER. EIGHT OF THESE ARE SPST TOGGLE SWITCHES USED FOR INPUTTING DATA AND INSTRUCTIONS TO THE COMPUTER WHEN OPERATING IN THE MANUAL MODE. IF THE SCELBI-8B FORMAT IS BEING FOLLOWED, USE MINIATURE OR SUBMINIATURE SWITCHES. THE CHASSIS DRAWINGS SHOW THE RECOMMENDED LAY-OUT ALONG WITH THE REFERENCE DESIGNATIONS ASSIGNED TO THE CONTROL SWITCHES. THREE OTHER SWITCHES FOR PROVIDING THE "INTERRUPT," "STEP," AND "RUN" FUNCTIONS ARE REQUIRED. THESE SWITCHES ARE STANDARD "NORMALLY OPEN" PUSH BUTTON OR MOMENTARY TOGGLE DEVICES.

CARD SOCKET INTERCONNECT WIRING

ONCE THE CARD SOCKETS HAVE BEEN MOUNTED IN THE CHASSIS OR OTHER FIXTURE ONE MAY PROCEED TO DO THE INTERCONNECT WIRING BETWEEN THE COMPUTER CARD SOCKETS. THE WIRING INFORMATION THAT FOLLOWS WAS GENERATED BY COMPUTER AND CONTAINS WIRING INFORMATION FOR A SYSTEM THAT MAY CONTAIN UP TO 16,384 WORDS OF MEMORY (ON 4 SCELBI TYPE 1107 OR 1109 MEMORY ELEMENT CARDS). BEFORE STARTING THE WIRING THE ASSEMBLER SHOULD ENSURE THAT THE REFERENCE DESIGNATIONS DISCUSSED ABOVE ARE UNDERSTOOD.

SCELBI RECOMMENDS THE USE OF 24 TO 30 GAUGE SOLID INSULATED WIRE FOR INTERCONNECTING THE CARD SOCKETS. CARE SHOULD BE TAKEN TO PREVENT SHORTS TO ADJACENT PINS AS WIRES ARE INSTALLED.

THE WIRE LIST THAT FOLLOWS FOR THE CARD SOCKET INTERCONNECT WIRING IS QUITE EASY TO UNDERSTAND. EACH CONNECTION POINT FOR A "WIRE RUN" IS LISTED. "WIRE RUNS" ARE GROUPED BY SIGNAL NOMENCLATURE AND SEPARATED BY A SOLID LINE. SINCE CONNECTION POINTS ARE LISTED, THE ACTUAL NUMBER OF WIRES IN A WIRE RUN IS $N - 1$ WHERE "N" IS THE NUMBER OF CONNECTION POINTS. FOR EXAMPLE, A WIRE RUN SHOWN AS:

XA01 B01 D0H
XA03 B-A D0H

INDICATES THAT A SINGLE WIRE IS TO BE RUN FROM SLOT XA01 (FRONT MOST CARD SLOT) PIN B01 (RIGHT SOCKET WHEN VIEWED FROM THE FRONT & FIRST PIN ON THE FRONT MOST PART OF THE SOCKET) OVER TO THE THIRD SLOT (XA03) ON THE RIGHT SOCKET PIN "A" (B-A). (AS VIEWED FROM THE TOP OF THE UNIT) THE LAST REFERENCE IN A LINE FOR A CONNECTION POINT IS THE SIGNAL NOMENCLATURE FOR THAT WIRE RUN. SIGNAL NOMENCLATURES ARE DERIVED FROM THE SCHEMATICS FOR THE VARIOUS SCELBI-8B CARDS. MULTI-WIRE RUNS MAY NOT SHOW THE CONNECTION POINTS IN THE BEST ROUTING SEQUENCE SO THE ASSEMBLER SHOULD REVIEW EACH WIRE RUN AND PICK THE BEST ROUTING SEQUENCE TO USE THE LEAST AMOUNT OF WIRE. MAKE A CHECK MARK AS YOU COMPLETE EACH CONNECTION BESIDE THE APPROPRIATE ENTRY ON THE WIRE LIST AS AN AID TO MAINTAINING YOUR PLACE AS YOU WORK.

SCELBI-8B P.C. SOCKET WIRING

XA01 B01 D0H
XA03 B-A D0H
XA05 B-L D0H

XA01 B09 D0L
XA03 B-K D0L

XA02 A07 D0N
XA03 A-H D0N

XA01 B02 D1H
XA03 B-B D1H
XA04 B-V D1H
XA05 B-M D1H

XA01 B10 D1L
XA03 B-L D1L

XA02 A08 D1N
XA03 A-J D1N

XA01 B03 D2H
XA03 B-C D2H
XA04 B-W D2H
XA05 B-N D2H

XA01 B11 D2L
XA03 B-M D2L

XA02 A09 D2N
XA03 A-K D2N

XA01 B04 D3H
XA03 B-D D3H
XA04 B-X D3H
XA05 B-P D3H

XA01 B12 D3L
XA03 B-N D3L

SCFLBI-8B P.C. SOCKET WIRING

XA02	A10	D3N
XA03	A-L	D3N

XA01	B05	D4H
XA02	B05	D4H
XA03	B-F	D4H
XA05	B-R	D4H

XA01	B13	D4L
XA03	B-P	D4L

XA02	A11	D4N
XA03	A-M	D4N

XA01	B06	D5H
XA02	B06	D5H
XA03	B-F	D5H
XA05	B-S	D5H

XA01	B14	D5L
XA03	B-R	D5L

XA02	B12	D5N
XA03	A-N	D5N

XA01	B07	D6H
XA02	B07	D6H
XA03	B-H	D6H
XA04	B-Y	D6H

XA01	B15	D6L
XA03	B-S	D6L

XA02	A13	D6N
XA03	A-P	D6N

XA01	B08	D7H
XA02	B08	D7H
XA03	B-J	D7H
XA04	B-Z	D7H

XA01	B16	D7L
XA03	B-T	D7L

XA02	A14	D7N
XA03	A-R	D7N

XA02	B19	HAS
XA03	B-W	HAS

XA01	A13	INT
XA02	A-T	INT

XA02	B17	LAS
XA03	B-V	LAS

XA02	A15	MD0N
XA04	A-S	MD0N

SCFLBI-8B P.C. SOCKET WIRING

```

XA02  A16  MD1N
XA04  A-T  MD1N
-----
XA02  A17  MD2N
XA04  A-U  MD2N
-----
XA02  A18  MD3N
XA04  A-V  MD3N
-----
XA02  A19  MD4N
XA04  A-W  MD4N
-----
XA02  A20  MD5N
XA04  A-X  MD5N
-----
XA02  A21  MD6N
XA04  A-Y  MD6N
-----
XA02  A22  MD7N
XA04  A-Z  MD7N
-----
XA01  A15  MIN0
XA04  A15  MIN0
-----
XA01  A16  MIN1
XA04  A16  MIN1
-----
XA01  A17  MIN2
XA04  A17  MIN2
-----
XA01  A18  MIN3
XA04  A18  MIN3
-----
XA01  A19  MIN4
XA04  A19  MIN4
-----
XA01  A20  MIN5
XA04  A20  MIN5
-----
XA01  A21  MIN6
XA04  A21  MIN6
-----
XA01  A22  MIN7
XA04  A22  MIN7
-----
XA02  B15  OPSN
XA03  B-U  OPSN
-----
XA02  B12  PCN
XA03  B17  PCN
-----
XA01  B-L  STOPN
XA02  B-L  STOPN
-----
XA02  A-U  S0
XA04  B-U  S0
-----

```

SCFLBI-8B P.C. SOCKET WIRING

XA01	B-J	T1N
XA02	B-J	T1N

XA01	B-F	T3N
XA02	B-F	T3N

XA03	A07	D0B
XA06	A-H	D0B
XA07	A-H	D0B
XA08	A-H	D0B
XA09	A-H	D0B

XA03	B-K	D0L
XA06	B-K	D0L
XA07	B-K	D0L
XA08	B-K	D0L
XA09	B-K	D0L

XA03	A08	D1B
XA06	A-J	D1B
XA07	A-J	D1B
XA08	A-J	D1B
XA09	A-J	D1B

XA03	B-L	D1L
XA06	B-L	D1L
XA07	B-L	D1L
XA08	B-L	D1L
XA09	B-L	D1L

XA03	A09	D2B
XA06	A-K	D2B
XA07	A-K	D2B
XA08	A-K	D2B
XA09	A-K	D2B

XA03	B-M	D2L
XA06	B-M	D2L
XA07	B-M	D2L
XA08	B-M	D2L
XA09	B-M	D2L

XA03	A10	D3B
XA06	A-L	D3B
XA07	A-L	D3B
XA08	A-L	D3B
XA09	A-L	D3B

XA03	B-N	D3L
XA06	B-N	D3L
XA07	B-N	D3L
XA08	B-N	D3L
XA09	B-N	D3L

SCELB1-8B P.C. SOCKET WIRING

XA03 A11 D4B
 XA06 A-M D4B
 XA07 A-M D4B
 XA08 A-M D4B
 XA09 A-M D4B

 XA03 B-P D4L
 XA06 B-P D4L
 XA07 B-P D4L
 XA08 B-P D4L
 XA09 B-P D4L

 XA03 A12 D5B
 XA06 A-N D5B
 XA07 A-N D5B
 XA08 A-N D5B
 XA09 A-N D5B

 XA03 B-R D5L
 XA06 B-R D5L
 XA07 B-R D5L
 XA08 B-R D5L
 XA09 B-R D5L

 XA03 A13 D6B
 XA06 A-P D6B
 XA07 A-P D6B
 XA08 A-P D6B
 XA09 A-P D6B

 XA03 B-S D6L
 XA06 B-S D6L
 XA07 B-S D6L
 XA08 B-S D6L
 XA09 B-S D6L

 XA03 A14 D7B
 XA06 A-R D7B
 XA07 A-R D7B
 XA08 A-R D7B
 XA09 A-R D7B

 XA03 B-T D7L
 XA06 B-T D7L
 XA07 B-T D7L
 XA08 B-T D7L
 XA09 B-T D7L

 XA04 A15 MIN0
 XA06 A-S MIN0
 XA07 A-S MIN0
 XA08 A-S MIN0
 XA09 A-S MIN0

SCFLBI-8B P.C. SOCKET WIRING

XA04 A16 MINI
 XA06 A-T MINI
 XA07 A-T MINI
 XA08 A-T MINI
 XA09 A-T MINI

 XA04 A17 MIN2
 XA06 A-U MIN2
 XA07 A-U MIN2
 XA08 A-U MIN2
 XA09 A-U MIN2

 XA04 A18 MIN3
 XA06 A-V MIN3
 XA07 A-V MIN3
 XA08 A-V MIN3
 XA09 A-V MIN3

 XA04 A19 MIN4
 XA06 A-W MIN4
 XA07 A-W MIN4
 XA08 A-W MIN4
 XA09 A-W MIN4

 XA04 A20 MIN5
 XA06 A-X MIN5
 XA07 A-X MIN5
 XA08 A-X MIN5
 XA09 A-X MIN5

 XA04 A21 MIN6
 XA06 A-Y MIN6
 XA07 A-Y MIN6
 XA08 A-Y MIN6
 XA09 A-Y MIN6

 XA04 A22 MIN7
 XA06 A-Z MIN7
 XA07 A-Z MIN7
 XA08 A-Z MIN7
 XA09 A-Z MIN7

 XA02 B-Z WRITE
 XA06 B-Z WRITE
 XA07 B-Z WRITE
 XA08 B-Z WRITE
 XA09 B-Z WRITE

 XA05 B-1 M0NX1
 XA06 B-1 M0NX1

 XA05 B-2 MINX1
 XA06 B-2 MINX1

 XA05 B-3 M2NX1
 XA06 B-3 M2NX1

SCELBI-8B P.C. SOCKET WIRING

XA05	B-4	M3NX1
XA06	B-4	M3NX1

XA05	B-5	M4NX1
XA06	B-5	M4NX1

XA05	B-6	M5NX1
XA06	B-6	M5NX1

XA05	B-7	M6NX1
XA06	B-7	M6NX1

XA05	B-8	M7NX1
XA06	B-8	M7NX1

XA05	B-9	M10NX1
XA06	B-9	M10NX1

XA05	B10	M11NX1
XA06	B10	M11NX1

XA05	B11	M12NX1
XA06	B11	M12NX1

XA05	B12	M13NX1
XA06	B12	M13NX1

XA05	B13	M14NX1
XA06	B13	M14NX1

XA05	B14	M15NX1
XA06	B14	M15NX1

XA05	B15	M16NX1
XA06	B15	M16NX1

XA05	B16	M17NX1
XA06	B16	M17NX1

XA05	B-A	M0NX2
XA07	B-1	M0NX2

XA05	B-B	M1NX2
XA07	B-2	M1NX2

XA05	B-C	M2NX2
XA07	B-3	M2NX2

XA05	B-D	M3NX2
XA07	B-4	M3NX2

XA05	B-E	M4NX2
XA07	B-5	M4NX2

XA05	B-F	M5NX2
XA07	B-6	M5NX2

SCELBI-8B P.C. SOCKET WIRING

XA05	B-K	M6NX2
XA07	B-7	M6NX2

XA05	B-J	M7NX2
XA07	B-8	M7NX2

XA05	B-U	M10NX2
XA07	B-9	M10NX2

XA05	B17	M11NX2
XA07	B10	M11NX2

XA05	B-V	M12NX2
XA07	B11	M12NX2

XA05	B18	M13NX2
XA07	B12	M13NX2

XA05	B-W	M14NX2
XA07	B13	M14NX2

XA05	B19	M15NX2
XA07	B14	M15NX2

XA05	B-X	M16NX2
XA07	B15	M16NX2

XA05	B20	M17NX2
XA07	B16	M17NX2

XA05	A-S	M0NX3
XA08	B-1	M0NX3

XA05	A-T	M1NX3
XA08	B-2	M1NX3

XA05	A-U	M2NX3
XA08	B-3	M2NX3

XA05	A-V	M3NX3
XA08	B-4	M3NX3

XA05	A-W	M4NX3
XA08	B-5	M4NX3

XA05	A-X	M5NX3
XA08	B-6	M5NX3

XA05	A-Y	M6NX3
XA08	B-7	M6NX3

XA05	A-Z	M7NX3
XA08	B-8	M7NX3

XA05	A22	M10NX3
XA08	B-9	M10NX3

SCFLBI-8B P.C. SOCKET WIRING

XA05	A21	M11NX3
XA08	B10	M11NX3

XA05	A20	M12NX3
XA08	B11	M12NX3

XA05	A19	M13NX3
XA08	B12	M13NX3

XA05	A18	M14NX3
XA08	B13	M14NX3

XA05	A17	M15NX3
XA08	B14	M15NX3

XA05	A16	M16NX3
XA08	B15	M16NX3

XA05	A15	M17NX3
XA08	B16	M17NX3

XA05	A-H	M0NX4
XA09	B-1	M0NX4

XA05	A-7	M1NX4
XA09	B-2	M1NX4

XA05	A-J	M2NX4
XA09	B-3	M2NX4

XA05	A-8	M3NX4
XA09	B-4	M3NX4

XA05	A-K	M4NX4
XA09	B-5	M4NX4

XA05	A-9	M5NX4
XA09	B-6	M5NX4

XA05	A-L	M6NX4
XA09	B-7	M6NX4

XA05	A10	M7NX4
XA09	B-8	M7NX4

XA05	A-M	M10NX4
XA09	B-9	M10NX4

XA05	A11	M11NX4
XA09	B10	M11NX4

XA05	A-N	M12NX4
XA09	B11	M12NX4

XA05	A12	M13NX4
XA09	B12	M13NX4

SCELBI-8B P.C. SOCKET WIRING

XA05	A-P	M14NX4
XA09	B13	M14NX4

XA05	A13	M15NX4
XA09	B14	M15NX4

XA05	A-R	M16NX4
XA09	B15	M16NX4

XA05	A14	M17NX4
XA09	B16	M17NX4

SECTION II

ASSEMBLY OF SCELBI-8B CHASSIS/FRONT PANEL UNIT

CUSTOMERS WHO PURCHASED THE SCELBI-8B CHASSIS KIT WILL RECEIVE A PRE-PUNCHED CHASSIS WITH THE SCELBI #1108 BACKPLANE HARNESS BOARD AND CARD SOCKETS INSTALLED. TO COMPLETE THE UNIT PROCEED AS FOLLOWS. (IF YOU ARE PROVIDING YOUR OWN CHASSIS UNIT YOU SHOULD PROCEED TO THE NEXT PAGE TO CONTINUE COMPLETING THE CHASSIS WIRING.)

1.) MOUNT THE 14 (11 PIN) I/O CONNECTORS AT THE REAR OF THE CHASSIS IN THE HOLES PROVIDED FOR THE "INP" AND "OUT" CONNECTORS. USE THE RETAINER CLIP RINGS PROVIDED TO FASTEN THE CONNECTORS TO THE UNIT. POSITION THE SOCKETS SO THAT THE SLOT (KEY) IS POINTING TOWARDS THE BOTTOM OF THE CHASSIS. (REFER TO THE CHASSIS DRAWINGS AT THE BEGINNING OF SECTION I IF NECESSARY.)

2.) INSTALL THE MALE (4 PIN) POWER CONNECTOR AT THE REAR OF THE CHASSIS USING A RETAINER CLIP RING. THE TWO LARGER PINS ON THE PLUG SHOULD BE TOWARDS THE TOP OF THE CHASSIS.

3.) INSTALL THE CARD GUIDES ON THE CARD SOCKETS AS PER THE ILLUSTRATION INCLUDED WITH THE GUIDES. MOUNT ONE GUIDE ON THE OUTER END OF EACH "PAIR" OF CARD SOCKETS.

4.) MOUNT THE FRONT PANEL UNIT TO THE CHASSIS USING THE 8 CHASSIS TOGGLE SWITCHES. INSTALL SEVERAL SWITCHES TO HOLD THE PANEL IN PLACE AND MAKE SURE ALL THE HOLES LINE UP BEFORE TIGHTENING THE SWITCH NUTS.

I M P O R T A N T

MAKE SURE THE TOGGLE SWITCHES ARE MOUNTED SO THAT THE SLOT IN THE SWITCH SHAFT IS POINTING UPWARDS! ADDITIONALLY, BE EXTREMELY CAREFUL WHEN TIGHTENING PANEL NUTS NOT TO MAR OR SCRATCH THE FINISH ON THE FRONT PANEL.

WHEN THE TOGGLE SWITCHES HAVE BEEN INSTALLED YOU MAY SLIDE A COLOR CODING SLEEVE ON EACH SWITCH LEVER. GREEN ON SWITCHES B7 & B6, YELLOW ON B5 THROUGH B3, AND RED ON B2 TO B0.

5.) INSTALL THE 3 PUSH BUTTON SWITCHES ON THE LEFT HAND SIDE OF THE UNIT. BE CAREFUL WHEN TIGHTENING THE NUTS NOT TO DAMAGE THE FRONT PANEL FINISH.

YOU HAVE NOW COMPLETED THE MECHANICAL ASSEMBLY OF THE SCELBI-8B CHASSIS KIT. YOU SHOULD PROCEED TO PERFORM THE CHASSIS WIRING BY GOING ON TO THE NEXT PAGE.

SCELBI-8B CHASSIS POWER BUSS WIRING

THE FOLLOWING WIRE RUNS DENOTE THE POWER CONNECTIONS IN A SCELBI-8B SYSTEM. IF YOU ARE PROVIDING YOUR OWN CHASSIS UNIT AND CARD SOCKETS, YOU SHOULD PROVIDE ALL THE CONNECTIONS LISTED. IF YOU PURCHASED THE SCELBI-8B CHASSIS KIT, THEN YOU ONLY HAVE TO CONNECT THE WIRES DESIGNATED BY A DOUBLE ASTERISK (***) AS THE REMAINING CONNECTIONS SHOWN IN THE LIST ARE INCLUDED ON THE SCELBI #1105 BACKPLANE HARNESS BOARD. YOU MAY REFER TO THE DRAWINGS SHOWN AT THE BEGINNING OF SECTION I FOR THE LOCATION AND PIN NUMBERS OF THE POWER CONNECTOR LOCATED AT THE REAR OF THE CHASSIS. PERSONS PROVIDING THEIR OWN CHASSIS AND POWER CONNECTOR SHOULD MAKE APPROPRIATE CONNECTIONS FROM THE POWER CONNECTOR TO THE CARD SOCKET PINS USING THE FOLLOWING LIST AS A GUIDELINE FOR CONNECTIONS TO THE CARD SOCKETS.

XA01	A-A	+5V BUSS	
XA01	A01	+5V BUSS	
XA02	A-A	+5V BUSS	
XA02	A01	+5V BUSS	
XA03	A-A	+5V BUSS	
XA03	A01	+5V BUSS	
XA04	A-A	+5V BUSS	
XA04	A01	+5V BUSS	
XA05	A-A	+5V BUSS	
XA05	A01	+5V BUSS	
XA06	A-A	+5V BUSS	
XA06	A01	+5V BUSS	
XA07	A-A	+5V BUSS	
XA07	A01	+5V BUSS	
XA08	A-A	+5V BUSS	
XA08	A01	+5V BUSS	
XA09	A-A	+5V BUSS	**
XA09	A01	+5V BUSS	**
P001	001	+5V BUSS	**

XA01	A-C	COM/GND	
XA01	A03	COM/GND	
XA02	A-C	COM/GND	
XA02	A03	COM/GND	
XA03	A-C	COM/GND	
XA03	A03	COM/GND	
XA04	A-C	COM/GND	
XA04	A03	COM/GND	
XA05	A-C	COM/GND	
XA05	A03	COM/GND	
XA06	A-C	COM/GND	
XA06	A03	COM/GND	
XA07	A-C	COM/GND	
XA07	A03	COM/GND	
XA08	A-C	COM/GND	
XA08	A03	COM/GND	
XA09	A-C	COM/GND	**
XA09	A03	COM/GND	**
P001	002	COM/GND	**
P001	003	COM/GND	**
SK06	011	COM/GND	**

XA01	A-E	-9V BUSS	
XA01	A05	-9V BUSS	
XA02	A-E	-9V BUSS	
XA02	A05	-9V BUSS	
XA06	A-E	-9V BUSS	
XA06	A05	-9V BUSS	
XA07	A-E	-9V BUSS	
XA07	A05	-9V BUSS	
XA08	A-E	-9V BUSS	
XA08	A05	-9V BUSS	
XA09	A-E	-9V BUSS	**
XA09	A05	-9V BUSS	**
P001	004	-9V BUSS	**

WIRING TO FRONT PANEL CONTROL SWITCHES

REFER TO THE BOTTOM VIEW DRAWING OF THE SCELBI-8B CHASSIS NEAR THE START OF SECTION I FOR THE POSITIONS OF CHASSIS SWITCHES AND THE TERMINAL DESIGNATIONS ON THE SWITCHES. INSTALL THE WIRES LISTED BELOW FROM THE DESIGNATED P.C. CARD SOCKET PINS TO THE CONTROL SWITCHES.

ADDITIONALLY, INSTALL THE JUMPER WIRES AT SLOT XA02 AS SHOWN IN THE LIST BELOW.

XA02	A-J	INT NC	(GND)
XA02	A-C	INT NC	(GND)

XA02	A-H	INT NO	
SI	TP2	INT NO	

XA04	A-F	INT0	
S11	TP2	INT0	

XA04	A06	INT1	
S10	TP2	INT1	

XA04	B17	INT2	
S9	TP2	INT2	

XA04	B18	INT3	
S8	TP2	INT3	

XA04	B19	INT4	
S7	TP2	INT4	

XA04	B20	INT5	
S6	TP2	INT5	

XA04	B21	INT6	
S5	TP2	INT6	

XA04	B22	INT7	
S4	TP2	INT7	

XA02	A-X	RDYN	
XA02	A-Z	RDYN	

XA02	A-Y	T3N	
XA02	B-F	T3N	

XA02	A-L	RUN	
S3	TP2	RUN	

XA02	A-N	STEP	
S2	TP2	STEP	

XA02	B-A	SYNC	
XA02	B-B	SYNC	

XA02	A-R	INT OP	(GND)
XA02	A-C	INT OP	(GND)

XA02 B-T TI IN

XA02 B-U TI IN

S1 TPI COM/GND
S2 TPI COM/GND
S3 TPI COM/GND
S4 TPI COM/GND
S5 TPI COM/GND
S6 TPI COM/GND
S7 TPI COM/GND
S8 TPI COM/GND
S9 TPI COM/GND
S10 TPI COM/GND
S11 TPI COM/GND
XA01 A03 COM/GND

SCELBI-8B INPUT/OUTPUT WIRING

BEFORE INSTALLING THE WIRES FROM THE P.C. CARD SOCKETS TO THE I/O (INPUT/OUTPUT) CONNECTORS YOU SHOULD HAVE COMPLETED THE BASIC P.C. CARD SOCKET WIRING AS DESCRIBED IN THE PREVIOUS PAGES. NOW, THE ONLY WIRING REQUIRED TO COMPLETE THE SCELBI-8B IS THE WIRING TO THE I/O CONNECTORS. THE WIRING OF THESE CONNECTORS IS DETAILED IN THE FOLLOWING PAGES.

IT SHOULD BE NOTED THAT IF YOU HAVE THE SCELBI-8B BASIC CARD SET, CONSISTING OF A #1100 CPU CARD, A #1101 DBB AND OUTPUT CARD, A #1102 INPUT CARD, A #1106 MEMORY EXPANSION CARD, A #1104 FRONT PANEL CARD, AND ONE OR MORE #1107 RAM MEMORY CARDS, THAT YOU CAN PLUG THOSE CARDS INTO THE P.C. CARD SOCKETS THAT YOU HAVE COMPLETED THE WIRING ON, PROVIDE POWER TO THE UNIT, AND HAVE AN OPERATIONAL SCELBI-8B MINICOMPUTER AT THIS POINT (WITHOUT ANY I/O CAPABILITY)! IF YOU DESIRE TO OPERATE YOUR SCELBI-8B UNIT PRIOR TO INSTALLING THE I/O WIRING REFER TO SECTION III WHICH DESCRIBES THE PROCEDURES TO FOLLOW FOR INITIAL INSTALLATION AND CHECK OUT OF THE SCELBI-8B CARD SET.

THE DRAWINGS SHOWN AT THE BEGINNING OF SECTION I SHOULD BE REFERRED TO WHEN DOING THE FOLLOWING WIRING. THOSE DRAWINGS SHOW THE POSITIONS OF THE I/O CONNECTORS AT THE REAR OF THE CHASSIS UNIT ALONG WITH THE SOCKET AND SOCKET PIN DESIGNATIONS. THE WIRING LIST THAT FOLLOWS WILL TELL YOU WHERE TO CONNECT WIRES BETWEEN I/O CONNECTORS AND BETWEEN THE I/O CONNECTORS AND PINS ON THE P.C. CARD SOCKETS, SO THAT YOUR SCELBI-8B WILL BE ABLE TO BE EASILY CONNECTED TO EXTERNAL (I/O) DEVICES.

AS WIRES ARE RUN FROM THE I/O CONNECTORS TO THE PRINTED CIRCUIT CONNECTORS YOU SHOULD FORM A BUNDLE UP THE MIDDLE OF THE CHASSIS THAT CAN EVENTUALLY BE TIED WITH CABLE TIES. IT IS OFTEN HELPFUL TO USE PIECES OF MASKING TAPE TO KEEP THE WIRES IN ORDER UNTIL THE WIRING HAS BEEN COMPLETED. THE WIRES SHOULD BE BRANCHED OFF TO THE PRINTED CIRCUIT CONNECTORS AS ILLUSTRATED IN THE DRAWING.

INTER-I/O CONNECTOR WIRING

USE 2 1/2 INCH PIECES OF WIRE STRIPPED 1/4 INCH AT EACH END AND INSTALL THE FOLLOWING WIRES TO FORM A "BUSS" SYSTEM ON THE I/O CONNECTORS AT THE BACK OF THE CHASSIS.

	FROM	TO	REF DESIG
()	SK6 PIN 11	SK12 PIN 11	SIG GND
()	SK6 PIN 11 (3S)	SK5 PIN 11	SIG GND
()	SK5 PIN 11 (2S)	SK4 PIN 11	SIG GND
()	SK4 PIN 11 (2S)	SK3 PIN 11	SIG GND
()	SK3 PIN 11 (2S)	SK2 PIN 11	SIG GND
()	SK2 PIN 11 (2S)	SK1 PIN 11 (1S)	SIG GND
()	SK12 PIN 11	SK13 PIN 11	SIG GND
()	SK13 PIN 11 (2S)	SK14 PIN 11 (1S)	SIG GND
()	SK12 PIN 11 (3S)	SK11 PIN 11	SIG GND

INTER-I/O CONNECTOR WIRING

	FROM	TO	REF DESIG
()	SK11 PIN 11 (2S)	SK10 PIN 11	SIG GND
()	SK10 PIN 11 (2S)	SK9 PIN 11	SIG GND
()	SK9 PIN 11 (2S)	SK8 PIN 11	SIG GND
()	SK8 PIN 11 (2S)	SK7 PIN 11 (1S)	SIG GND
()	SK7 PIN 1 (1S)	SK8 PIN 1	D0L
()	SK8 PIN 1 (2S)	SK9 PIN 1	D0L
()	SK9 PIN 1 (2S)	SK10 PIN 1	D0L
()	SK10 PIN 1	SK11 PIN 1	D0L
()	SK11 PIN 1 (2S)	SK12 PIN 1	D0L
()	SK12 PIN 1 (2S)	SK13 PIN 1	D0L
()	SK13 PIN 1 (2S)	SK14 PIN 1 (1S)	D0L
()	SK7 PIN 2 (1S)	SK8 PIN 2	D1L
()	SK8 PIN 2 (2S)	SK9 PIN 2	D1L
()	SK9 PIN 2 (2S)	SK10 PIN 2	D1L
()	SK10 PIN 2	SK11 PIN 2	D1L
()	SK11 PIN 2 (2S)	SK12 PIN 2	D1L
()	SK12 PIN 2 (2S)	SK13 PIN 2	D1L
()	SK13 PIN 2 (2S)	SK14 PIN 2 (1S)	D1L
()	SK7 PIN 3 (1S)	SK8 PIN 3	D2L
()	SK8 PIN 3 (2S)	SK9 PIN 3	D2L
()	SK9 PIN 3 (2S)	SK10 PIN 3	D2L
()	SK10 PIN 3	SK11 PIN 3	D2L
()	SK11 PIN 3 (2S)	SK12 PIN 3	D2L
()	SK12 PIN 3 (2S)	SK13 PIN 3	D2L
()	SK13 PIN 3 (2S)	SK14 PIN 3 (1S)	D2L
()	SK7 PIN 4 (1S)	SK8 PIN 4	D3L
()	SK8 PIN 4 (2S)	SK9 PIN 4	D3L
()	SK9 PIN 4 (2S)	SK10 PIN 4	D3L

INTFR-I/O CONNECTOR WIRING

	FROM	TO	REF DESIG
()	SK10 PIN 4	SK11 PIN 4	D3L
()	SK11 PIN 4 (2S)	SK12 PIN 4	D3L
()	SK12 PIN 4 (2S)	SK13 PIN 4	D3L
()	SK13 PIN 4 (2S)	SK14 PIN 4 (1S)	D3L
()	SK7 PIN 5 (1S)	SK8 PIN 5	D4L
()	SK8 PIN 5 (2S)	SK9 PIN 5	D4L
()	SK9 PIN 5 (2S)	SK10 PIN 5	D4L
()	SK10 PIN 5 (2S)	SK11 PIN 5	D4L
()	SK11 PIN 5	SK12 PIN 5	D4L
()	SK12 PIN 5 (2S)	SK13 PIN 5	D4L
()	SK13 PIN 5 (2S)	SK14 PIN 5 (1S)	D4L
()	SK7 PIN 6 (1S)	SK8 PIN 6	D5L
()	SK8 PIN 6 (2S)	SK9 PIN 6	D5L
()	SK9 PIN 6 (2S)	SK10 PIN 6	D5L
()	SK10 PIN 6 (2S)	SK11 PIN 6	D5L
()	SK11 PIN 6	SK12 PIN 6	D5L
()	SK12 PIN 6 (2S)	SK13 PIN 6	D5L
()	SK13 PIN 6 (2S)	SK14 PIN 6 (1S)	D5L
()	SK7 PIN 7 (1S)	SK8 PIN 7	D6L
()	SK8 PIN 7 (2S)	SK9 PIN 7	D6L
()	SK9 PIN 7 (2S)	SK10 PIN 7	D6L
()	SK10 PIN 7 (2S)	SK11 PIN 7	D6L
()	SK11 PIN 7	SK12 PIN 7	D6L
()	SK12 PIN 7 (2S)	SK13 PIN 7	D6L
()	SK13 PIN 7 (2S)	SK14 PIN 7 (1S)	D6L
()	SK7 PIN 8 (1S)	SK8 PIN 8	D7L
()	SK8 PIN 8 (2S)	SK9 PIN 8	D7L
()	SK9 PIN 8 (2S)	SK10 PIN 8	D7L

INTER-I/O CONNECTOR WIRING

	FROM	TO	REF DESIG
()	SK10 PIN 8 (2S)	SK11 PIN 8	D7L
()	SK11 PIN 8	SK12 PIN 8	D7L
()	SK12 PIN 8 (2S)	SK13 PIN 8	D7L
()	SK13 PIN 8 (2S)	SK14 PIN 8 (1S)	D7L

OUTPUT DATA BUSS WIRING

THE FOLLOWING WIRES CONNECT THE DATA BUSS FOR THE OUTPUT PORTS (INSTALLED ON THE I/O CONNECTORS BY THE WIRING JUST COMPLETED) TO THE SCELBI-5B MINI-COMPUTER. TO INSTALL THESE WIRES STRIP ONE END OF A PIECE OF WIRE 1/4 OF AN INCH AND CONNECT THE STRIPPED END TO THE DESIGNATED PIN ON THE I/O CONNECTOR, THEN ROUTE THE WIRE UP THE CENTER OF THE CHASSIS UNTIL IT ALMOST REACHES THE PRINTED CIRCUIT CONNECTOR IN SLOT XA9, THEN BEND THE WIRE AT A RIGHT ANGLE AND RUN IT PARALLEL WITH THE PRINTED CIRCUIT CARD SOCKET UNTIL IT REACHES THE DESIGNATED PIN. NOW, LEAVE ABOUT 3/4 INCH ADDITIONAL WIRE, CUT AND STRIP THE WIRE 1/4 OF AN INCH AND MAKE THE CONNECTION AT THE PRINTED CIRCUIT CARD SOCKET. AS THE WIRES ARE INSTALLED KEEP THEM NEATLY DRESSED IN A BUNDLE, USING PIECES OF MASKING TAPE IF NECESSARY. ALL THE WIRES GOING TO THE CARD SOCKETS WILL FORM A CABLE THAT WILL BE SECURED WITH TIE-WRAPS WHEN THE WIRING HAS BEEN COMPLETED.

	FROM	TO	REF DESIG
()	SK10 PIN 1 (3S)	XA9 PIN B-K (1S)	D0L
()	SK10 PIN 2 (3S)	XA9 PIN B-L (1S)	D1L
()	SK10 PIN 3 (3S)	XA9 PIN B-M (1S)	D2L
()	SK10 PIN 4 (3S)	XA9 PIN B-N (1S)	D3L
()	SK11 PIN 5 (3S)	XA9 PIN B-P (1S)	D4L
()	SK11 PIN 6 (3S)	XA9 PIN B-R (1S)	D5L
()	SK11 PIN 7 (3S)	XA9 PIN B-S (1S)	D6L
()	SK11 PIN 8 (3S)	XA9 PIN B-T (1S)	D7L

OUTPUT STROBE WIRING

THE FOLLOWING WIRES CONNECT THE OUTPUT STROBE LINES FOR THE OUTPUT PORTS FROM THE DBB & OUTPUT CARD THAT RESIDES IN SLOT XA3. RUN THE WIRES FROM THE DESIGNATED OUTPUT SOCKET UP THE MIDDLE OF THE CHASSIS AND THEN OVER TO THE APPROPRIATE PIN ON THE CARD SOCKET.

OUTPUT STROBE WIRING

	FROM	TO	REF DESIG
()	SK7 PIN 9 (1S)	XA3 PIN A15 (1S)	0S0
()	SK8 PIN 9 (1S)	XA3 PIN A16 (1S)	0S1
()	SK9 PIN 9 (1S)	XA3 PIN A17 (1S)	0S2
()	SK10 PIN 9 (1S)	XA3 PIN A18 (1S)	0S3
()	SK11 PIN 9 (1S)	XA3 PIN A19 (1S)	0S4
()	SK12 PIN 9 (1S)	XA3 PIN A20 (1S)	0S5
()	SK13 PIN 9 (1S)	XA3 PIN A21 (1S)	0S6
()	SK14 PIN 9 (1S)	XA3 PIN A22 (1S)	0S7

INPUT PORT WIRING

THE FOLLOWING WIRES CONNECT THE INPUT PORT CONNECTORS TO THE INPUT CARD THAT RESIDES IN SLOT XA4. RUN THE WIRES FROM THE DESIGNATED INPUT SOCKET UP THE MIDDLE OF THE CHASSIS AND THEN OVER TO THE APPROPRIATE PIN ON THE CARD SOCKET.

	FROM	TO	REF DESIG
()	SK1 PIN 1 (1S)	XA4 PIN A-H (1S)	INP00
()	SK1 PIN 2 (1S)	XA4 PIN A-J (1S)	INP01
()	SK1 PIN 3 (1S)	XA4 PIN A-K (1S)	INP02
()	SK1 PIN 4 (1S)	XA4 PIN A-L (1S)	INP03
()	SK1 PIN 5 (1S)	XA4 PIN A-M (1S)	INP04
()	SK1 PIN 6 (1S)	XA4 PIN A-N (1S)	INP05
()	SK1 PIN 7 (1S)	XA4 PIN A-P (1S)	INP06
()	SK1 PIN 8 (1S)	XA4 PIN A-R (1S)	INP07
()	SK2 PIN 1 (1S)	XA4 PIN A7 (1S)	INP10
()	SK2 PIN 2 (1S)	XA4 PIN A8 (1S)	INP11
()	SK2 PIN 3 (1S)	XA4 PIN A9 (1S)	INP12
()	SK2 PIN 4 (1S)	XA4 PIN A10 (1S)	INP13
()	SK2 PIN 5 (1S)	XA4 PIN A11 (1S)	INP14
()	SK2 PIN 6 (1S)	XA4 PIN A12 (1S)	INP15

INPUT PORT WIRING

	FROM	TO	REF DESIG
()	SK2 PIN 7 (1S)	XA4 PIN A13 (1S)	INP16
()	SK2 PIN 8 (1S)	XA4 PIN A14 (1S)	INP17
()	SK3 PIN 1 (1S)	XA4 PIN B-A (1S)	INP20
()	SK3 PIN 2 (1S)	XA4 PIN B-B (1S)	INP21
()	SK3 PIN 3 (1S)	XA4 PIN B-C (1S)	INP22
()	SK3 PIN 4 (1S)	XA4 PIN B-D (1S)	INP23
()	SK3 PIN 5 (1S)	XA4 PIN B-F (1S)	INP24
()	SK3 PIN 6 (1S)	XA4 PIN B-F (1S)	INP25
()	SK3 PIN 7 (1S)	XA4 PIN B-H (1S)	INP26
()	SK3 PIN 8 (1S)	XA4 PIN B-J (1S)	INP27
()	SK4 PIN 1 (1S)	XA4 PIN B1 (1S)	INP30
()	SK4 PIN 2 (1S)	XA4 PIN B2 (1S)	INP31
()	SK4 PIN 3 (1S)	XA4 PIN B3 (1S)	INP32
()	SK4 PIN 4 (1S)	XA4 PIN B4 (1S)	INP33
()	SK4 PIN 5 (1S)	XA4 PIN B5 (1S)	INP34
()	SK4 PIN 6 (1S)	XA4 PIN B6 (1S)	INP35
()	SK4 PIN 7 (1S)	XA4 PIN B7 (1S)	INP36
()	SK4 PIN 8 (1S)	XA4 PIN B8 (1S)	INP37
()	SK5 PIN 1 (1S)	XA4 PIN B-K (1S)	INP40
()	SK5 PIN 2 (1S)	XA4 PIN B-L (1S)	INP41
()	SK5 PIN 3 (1S)	XA4 PIN B-M (1S)	INP42
()	SK5 PIN 4 (1S)	XA4 PIN B-N (1S)	INP43
()	SK5 PIN 5 (1S)	XA4 PIN B-P (1S)	INP44
()	SK5 PIN 6 (1S)	XA4 PIN B-R (1S)	INP45
()	SK5 PIN 7 (1S)	XA4 PIN B-S (1S)	INP46
()	SK5 PIN 8 (1S)	XA4 PIN B-T (1S)	INP47
()	SK6 PIN 1 (1S)	XA4 PIN B9 (1S)	INP50
()	SK6 PIN 2 (1S)	XA4 PIN B10 (1S)	INP51

INPUT PORT WIRING

	FROM	TO	REF DESIG
()	SK6 PIN 3 (1S)	XA4 PIN B11 (1S)	INP52
()	SK6 PIN 4 (1S)	XA4 PIN B12 (1S)	INP53
()	SK6 PIN 5 (1S)	XA4 PIN B13 (1S)	INP54
()	SK6 PIN 6 (1S)	XA4 PIN B14 (1S)	INP55
()	SK6 PIN 7 (1S)	XA4 PIN B15 (1S)	INP56
()	SK6 PIN 8 (1S)	XA4 PIN B16 (1S)	INP57

YOU HAVE NOW COMPLETED THE WIRING FOR THE SCELBI-8B CHASSIS. AT THIS TIME IT IS GENERALLY A GOOD IDEA TO TAKE A FEW MINUTES TO PERFORM A CHECK OF THE WIRING YOU HAVE INSTALLED. USE AN OHM-METER OR CIRCUIT CONTINUITY TESTER AND GO BACK OVER THE WIRING LIST TO MAKE SURE THAT EACH WIRE HAS BEEN CONNECTED TO THE PROPER POINT. WHEN YOU HAVE RECHECKED YOUR WORK YOU MAY USE THE PLASTIC TIE-WRAPS AT SEVERAL PLACES ALONG THE WIRES YOU HAVE INSTALLED TO FORM A NEAT AND STURDY CABLE.

YOUR CHASSIS IS READY TO ACCEPT THE SCELBI-8B MINI-COMPUTER CARD SET. PROCEED TO THE SECTION ON INITIAL INSTALLATION AND CHECK OUT OF YOUR SCELBI-8B MINI-COMPUTER!

SECTION III

SCELBI-8B INITIAL INSTALLATION AND CHECK OUT PROCEDURES

INITIAL INSTALLATION AND CHECK OUT OF THE SCELBI-8B MINICOMPUTER IS STRAIGHT FORWARD. THE PROCEDURE CONSIST ESSENTIALLY OF CONNECTING A POWER SUPPLY, PLUGGING THE CARDS INTO THE APPROPRIATE CARD SOCKETS, AND VERIFYING PROPER OPERATION BY LOADING AND EXECUTING SEVERAL SIMPLE PROGRAMS.

CONNECTION OF THE POWER SUPPLY

THE SCELBI-8B MINICOMPUTER REQUIRES A POWER SUPPLY CAPABLE OF DELIVERING +5 VOLTS AND -9 VOLTS (PLUS OR MINUS 5%). THE CURRENT REQUIREMENTS OF THE SUPPLY DEPEND ON THE AMOUNT OF MEMORY IN THE SYSTEM (AND ANY ADDITIONAL PERIPHERAL UNITS WHICH MAY BE CONNECTED TO THE SUPPLY). THE AMOUNT OF CURRENT THAT THE POWER SUPPLY MUST BE CAPABLE OF DELIVERING FOR A PARTICULAR SYSTEM CAN BE CALCULATED USING THE CURRENT VALUES GIVEN IN THE TECHNICAL DESCRIPTION SECTION OF THE SCELBI-8B USER'S MANUAL.

IF YOU PURCHASED A SCELBI POWER SUPPLY WITH YOUR SYSTEM, YOU NEED ONLY TO CONNECT THE POWER SUPPLY TO THE COMPUTER V.I.A. THE POWER CABLE PROVIDED. IF YOU ARE PROVIDING YOUR OWN SUPPLY, YOU MAY WANT TO INSTALL THE 4 PIN FEMALE POWER CONNECTOR PROVIDED WITH THE SCELBI-8B CHASSIS UNIT ON YOUR POWER SUPPLY. THIS CONNECTOR MATES WITH THE POWER CABLE TO PROVIDE A QUICK AND EASY CONNECTION METHOD. THE PIN ASSIGNMENTS FOR THE POWER CABLE ARE SHOWN BELOW.

POWER CONNECTOR PIN #1: +5 VOLTS

POWER CONNECTOR PIN #2: D.C. COMMON/SIGNAL GROUND

POWER CONNECTOR PIN #3: D.C. COMMON/SIGNAL GROUND

POWER CONNECTOR PIN #4: -9 VOLTS

IF YOU HAVE PROVIDED YOUR OWN SUPPLY IT IS RECOMMENDED THAT YOU PERFORM A TEST TO ENSURE THAT YOUR POWER SUPPLY CONNECTIONS ARE CORRECT BEFORE PLUGGING IN THE SCELBI-8B COMPUTER CARD SET TO THE CHASSIS UNIT. TO DO THIS, SIMPLY TURN ON YOUR POWER SUPPLY AFTER IT HAS BEEN CONNECTED TO THE CHASSIS UNIT AND VERIFY THAT +5 VOLTS IS PRESENT BETWEEN PINS A1 (+5) AND A3 (COMMON) AS WELL AS BETWEEN AA (15) AND AC (COMMON) ON THE "A" CARD SOCKETS. THEN ASCERTAIN THAT -9 VOLTS IS PRESENT BETWEEN PINS A5 (-9) AND A3 (COMMON) AS WELL AS PINS AE (-9) AND AC (COMMON). BE SURE THAT THE VOLTAGE POLARITY IS CORRECT!

N O T I C E

IT IS EXTREMELY IMPORTANT THAT CORRECT VOLTAGE POLARITY EXISTS TO THE SCELBI-8B COMPUTER CARDS. WHILE EACH SCELBI CARD IS FUSED AND DIODE PROTECTED AS A PRECAUTION AGAINST INCORRECT POWER CONNECTIONS (AS WELL AS OVER-VOLTAGE) THESE PROTECTION CIRCUITS ARE INTENDED ONLY TO SERVE AS MOMENTARY PROTECTIVE DEVICES. SCELBI CARDS THAT HAVE BEEN DAMAGED BECAUSE OF THE APPLICATION OF INCORRECT VOLTAGES ARE NOT COVERED BY THE SCELBI WARRANTY.

INSTALLATION OF CARDS

BEFORE PLUGGING IN THE SCELBI-8B CARD SET MAKE CERTAIN THAT THE POWER SUPPLY TO THE UNIT IS TURNED OFF. NEVER PLUG, OR UNPLUG, CARDS INTO THE CHASSIS UNIT WHEN POWER IS CONNECTED.

REFER TO THE TOP VIEW CHASSIS DRAWING PROVIDED WITH THIS DOCUMENTATION AND INSTALL CARDS INTO THE CHASSIS UNIT AS FOLLOWS. MAKE SURE THE COMPONENT SIDE OF THE CARDS IS FACING TOWARDS THE FRONT OF THE CHASSIS UNIT.

PLUG THE #1104 FRONT PANEL CARD INTO SLOT #1 (FRONT-MOST SLOT)

PLUG THE #1100 CPU CARD INTO SLOT #2.

PLUG THE #1101 DBB & OUTPUT CARD INTO SLOT #3.

PLUG THE #1102 INPUT CARD INTO SLOT #4.

PLUG THE #1106 MEMORY EXPANDER CARD INTO SLOT #5.

PLUG #1107 RAM OR #1109 ROM/PROM CARDS INTO SLOTS #6 - 9 AS APPROPRIATE REMEMBERING THAT THE SLOT POSITION CHOSEN WILL SELECT THE "PAGE NUMBERS" OF MEMORY THAT WILL BE SELECTED. THE "PAGE NUMBERS" ENABLED BY EACH MEMORY CARD SLOT POSITION ARE GIVEN IN THE TOP VIEW CHASSIS DRAWING REFERENCED ABOVE.

INITIAL OPERATION

WHEN THE CARDS HAVE BEEN INSTALLED IN THEIR APPROPRIATE SLOTS YOUR SCELBI-8B MINICOMPUTER IS READY TO OPERATE.

APPLY POWER TO THE UNIT AND IMMEDIATELY OBSERVE THE POWER INDICATOR LAMPS ON THE FRONT PANEL CARD TO VERIFY THAT THE +5 AND -9 VOLTAGES ARE PRESENT. NEVER ATTEMPT TO OPERATE THE SCELBI-8B IF EITHER VOLTAGE IS ABSENT.

WITH PROPER POWER APPLIED TO THE UNIT YOU MAY NOW PROCEED TO START OPERATING YOUR SCELBI-8B. YOU SHOULD FAMILIARIZE YOURSELF WITH THE INFORMATION IN THE SCELBI-8B USER'S MANUAL. SECTION THREE (PINK SECTION) IN THE MANUAL PRESENTS DETAILED OPERATING INSTRUCTIONS.

TO START OPERATIONS YOU SHOULD TURN TO PAGE 5 OF SECTION 3 IN THE SCELBI-8B USER'S MANUAL AND FOLLOW THE INSTRUCTIONS FOR INITIALIZING THE SCELBI-8B FOLLOWING POWER TURN-ON. IT IS THEN SUGGESTED THAT YOU PROCEED TO LOAD AND HAVE THE COMPUTER PERFORM THE SMALL "JUMP TO ITSELF" PROGRAM THAT IS ILLUSTRATED STARTING ON PAGE 7 OF SECTION 3.

YOU MIGHT THEN LOAD AND EXECUTE THE SIMPLE MEMORY DIAGNOSTIC PROGRAM DESCRIBED STARTING ON PAGE 21 OF SECTION 3 OF THE MANUAL.

YOU MAY THEN GO ON TO LOAD AND EXECUTE THE LIGHT FLASHER PROGRAM DESCRIBED ON PAGE 27 IN SECTION 3.

OR, YOU MAY START TO DEVELOP AND EXECUTE YOUR OWN PROGRAMS, OR LOAD AND OPERATE SCELBI PROGRAMS.

IF YOU HAVE PURCHASED SCELBI PERIPHERAL UNITS, THE CONNECTION AND OPERATION OF THOSE UNITS WILL BE COVERED BY DOCUMENTATION PROVIDED WITH THOSE DEVICES.

IN CASE OF DIFFICULTY

SHOULD IMPROPER OPERATION OCCUR DURING THE CHECK OUT PROCEDURES WE SUGGEST THAT YOU FIRST CHECK THAT THE P.C. CARDS ARE PROPERLY SEATED IN THEIR SOCKETS. THE NEXT STEP IF THE DIFFICULTY PERSISTS WOULD BE TO RECHECK ANY WIRING THAT YOU INSTALLED, TO VERIFY THAT THE POWER SUPPLY VOLTAGES ARE CORRECT AND PROPERLY CONNECTED TO THE SCELBI-8B, AND THAT YOU MAKE CERTAIN YOU ARE OPERATING THE UNIT CORRECTLY. CUSTOMERS WHO ASSEMBLED CARD SETS MAY WANT TO REFER TO THE SECTION PROVIDED AT THE END OF THE DISCUSSION ON CARD ASSEMBLIES WHICH PROVIDES SOME ADVICE ON THE INITIAL CHECKING OF INDIVIDUAL CARDS SHOULD DIFFICULTIES ARISE WHEN THE CARDS ARE FIRST INSTALLED.

N O T E

IF YOU ARE NOT FAMILIAR WITH THE OPERATION OF A COMPUTER YOU SHOULD BE ADVISED THAT THE MOST COMMON SOURCE OF PROBLEMS WITH THE MACHINE ARE THE RESULT OF "OPERATOR ERRORS." SINCE THE MACHINE IS FULLY PROGRAMMABLE - IT WILL (INDEED IS ONLY ABLE TO) FOLLOW PRECISELY THE INSTRUCTIONS GIVEN TO IT BY THE OPERATOR OR PROGRAM RESIDING IN MEMORY. IF YOU THINK THE COMPUTER IS NOT OPERATING CORRECTLY WE ADVISE YOU TO CAREFULLY RECHECK THE PROGRAM OR INSTRUCTIONS YOU ARE ASKING IT TO PERFORM BEFORE JUMPING TO ANY CONCLUSION THAT THE MACHINE IS MALFUNCTIONING. FROM YEARS OF EXPERIENCE WE AT SCELBI CAN ADVISE YOU THAT THE NEWCOMER TO MINICOMPUTER PROGRAMMING AND OPERATION WILL MAKE MANY MISTAKES BEFORE BECOMING AN ADEPT PROGRAMMER, AND THERE SEEMS TO BE A NATURAL TENDENCY FOR THE NEW PROGRAMMER TO IMMEDIATELY ASSUME THAT THE MACHINE IS NOT OPERATING CORRECTLY WHEN A PROGRAM DOES NOT PERFORM AS THE NOVICE PROGRAMMER INTENDED. AS A GENERAL RULE OF THUMB, WHEN A PROGRAM DOES NOT PERFORM PROPERLY, THE LAST THING TO CONSIDER IS A HARDWARE MALFUNCTION.

DOCUMENTATION

YOUR SCELBI-8B USER'S MANUAL CONTAINS FULL DOCUMENTATION INCLUDING SCHEMATICS, ASSEMBLY DRAWINGS AND WIRE LIST(S), AND PARTS LISTS FOR THE INDIVIDUAL CARDS. YOU MAY REFER TO THOSE DRAWINGS TO GAIN INSIGHT INTO THE MACHINE'S OPERATION, OR AS TECHNICAL REFERENCES SHOULD TROUBLE EVER OCCUR WITH YOUR SYSTEM.

MAINTENANCE PROCEDURES

THE ONLY NORMAL MAINTENANCE REQUIRED BY THE SCELBI-8B IS THAT THE UNIT BE PERIODICALLY DUSTED TO PREVENT EXCESSIVE HEAT FROM BUILDING UP AROUND COMPONENTS. A SMALL, SOFT, CLEAN PAINT BRUSH IS AN IDEAL TOOL TO USE TO CLEAN THE PRINTED CIRCUIT CARDS OF DUST.

TECHNICAL INFORMATION

A MINIMUM SCELBI-8B MINICOMPUTER CONSISTS OF A SET OF SIX P.C. CARDS (DESCRIBED IN DETAIL LATER IN THIS SECTION) WHICH PLUG INTO P.C. CARD SOCKETS. THE SOCKETS MAY BE INTER-CONNECTED BY HAND WIRING IF DESIRED. HOWEVER, CUSTOMERS WHO PURCHASE A SCELBI-8B CHASSIS ARE PROVIDED WITH A DOUBLE-SIDED BACK PLANE HARNESS BOARD THAT ELIMINATES ABOUT 15 HOURS OF HAND WIRING. THE USE OF A PRINTED CIRCUIT BACK PLANE HARNESS BOARD ALSO GREATLY ENHANCES THE LONG TERM RELIABILITY OF THE SCELBI-8B MINICOMPUTER. THE STANDARD SCELBI-8B CHASSIS WITH THE BACK PLANE HARNESS CARD HAS P.C. CARD SOCKETS FOR EXPANDING THE MEMORY CAPACITY OF THE SYSTEM UP TO 16,384 WORDS BY SIMPLY PLUGGING IN ADDITIONAL MEMORY CARDS. THE SCELBI-8B CHASSIS HAS 11 SWITCHES ALONG THE FRONT WHICH SERVE AS THE COMPUTER OPERATOR'S CONSOLE SWITCHES. THE REAR APRON OF THE CHASSIS HOLDS 14 I/O CONNECTORS AND A POWER CONNECTOR. PICTORIALS OF THE BASIC CHASSIS STRUCTURE ARE ILLUSTRATED IN THE CHASSIS ASSEMBLY INSTRUCTIONS SECTION OF THIS CHAPTER.

THE ENTIRE SCELBI-8B MINICOMPUTER MEASURES APPROXIMATELY 13 INCHES IN WIDTH, BY 11 INCHES IN HEIGHT BY 10 INCHES IN DEPTH. A 16 K WORD UNIT WEIGHS ABOUT 8 POUNDS. AN OPTIONAL CABINET IN WHICH TO HOUSE THE CHASSIS UNIT IS AVAILABLE.

PRINTED CIRCUIT CARDS USED IN THE SCELBI-8B ARE MADE OF COMMERCIAL GRADE GLASS EPOXY (G10) MATERIAL. CARDS HAVE TWO OUNCE TINNED COPPER LANDS ON BOTH SIDES AND PLATED-THROUGH HOLES ARE USED TO CONNECT FOIL PATTERNS THROUGH THE CARD. THE STANDARD CARD SIZE IS 9 INCHES WIDE BY 6.4 INCHES IN HEIGHT (INCLUDING THE CONNECTOR FINGERS). THE STANDARD CARDS PLUG INTO PAIRS OF 44 PIN P.C. CARD SOCKETS WHICH HAVE A SPACING OF 0.156 INCHES BETWEEN CONTACTS. (AMPHENOL TYPE 22221-404 OR EQUIVALENT SOCKETS.)

A SEPARATE POWER SUPPLY CAPABLE OF DELIVERING PLUS FIVE VOLTS AND MINUS 9 VOLTS IS REQUIRED BY THE COMPUTER. CURRENT REQUIREMENTS DEPEND ON THE AMOUNT OF MEMORY IN A SYSTEM (AND THE NUMBER OF PERIPHERAL UNITS THAT UTILIZE THE SUPPLY). POWER REQUIREMENTS FOR INDIVIDUAL COMPUTER CARDS USED IN THE SCELBI-8B SYSTEM ARE SPECIFIED IN THE TECHNICAL DESCRIPTION FOR EACH CARD.

BRIEF FUNCTIONAL DESCRIPTION OF THE SCELBI-8B CARD SYSTEM

THE OVER ALL OPERATION OF A SCELBI-8B MINICOMPUTER CENTERS AROUND THE SCELBI #1100 CPU CARD. THIS CARD CONTAINS AN INTEL '8008' "CPU-ON-A-CHIP," A MASTER CLOCK CIRCUIT FOR PROVIDING TIMING FOR THE SYSTEM, AND A NETWORK OF STATE CONTROL AND MULTIPLEXING LOGIC.

A BI-DIRECTIONAL ADDRESS/DATA BUSS ON THE 8008 INTEGRATED CIRCUIT FEEDS ADDRESSES/DATA FROM THE CHIP TO BUFFERS ON THE CPU CARD. THE DATA/ADDRESSES ARE THEN SENT TO THE SCELBI #1101 DBB (DATA BUSS BUFFER) AND OUTPUT CARD WHERE IT IS LATCHED AND BUFFERED FOR FURTHER DISTRIBUTION. THE OUTPUTS OF THE LATCHES ON THE #1101 DBB & OUTPUT CARD ARE USED TO SELECT MEMORY ADDRESSES OR I/O PORTS DEPENDING ON THE TYPE OF INSTRUCTIONS BEING PERFORMED. THE #1101 CONTAINS LOGIC TO DECODE MEMORY ADDRESSES FROM PAGE 00 TO PAGE 17 BUT THIS LOGIC IS NOT UTILIZED IN A STANDARD SCELBI-8B SYSTEM. THE #1101 CARD ALSO HAS CIRCUITS THAT DECODE THE OUTPUT PORT SELECT STROBE SIGNAL FOR ANY ONE OF 16 OUTPUT PORTS. (IN A STANDARD SCELBI-8B SYSTEM, ONLY THE FIRST EIGHT OF THESE OUTPUT STROBES ARE WIRED TO I/O CONNECTORS ON THE CHASSIS.) BUFFERED

DATA FROM THE #1101 CARD IS MADE AVAILABLE TO THE MEMORY BANKS IN THE SYSTEM AS WELL AS TO THE I/O PORTS.

SIX OF THE LATCHED HIGH ADDRESS LINES FROM THE #1101 CARD ARE FED TO THE #1106 MEMORY EXPANDER CARD. LOGIC ON THE #1106 CARD SELECTS ANY ONE OF 64 SECTIONS OF MEMORY. EACH SECTION (CALLED A "PAGE") CONSISTS OF 256 BYTES OF MEMORY. INDIVIDUAL BYTES ON A PAGE ARE SELECTED BY THE LATCHED LOW ADDRESS LINES FED FROM THE #1101 CARD TO THE #1107 RAM MEMORY OR #1109 ROM/PROM MEMORY CARDS. THE "PAGE" SELECT LINES FROM THE #1106 MEMORY EXPANDER CARD ARE ROUTED TO THE RAM OR ROM/PROM MEMORY CARDS IN THE SYSTEM.

THE BUFFERED BI-DIRECTIONAL ADDRESS/DATA BUSS ON THE #1100 CPU CARD IS ABLE TO RECEIVE DATA DURING MULTIPLEXED "RECEIVE" TIMING PERIODS FROM THE #1102 INPUT CARD. THE #1102 INPUT CARD CONTAINS MULTIPLEXING LOGIC WHICH SELECTS AND PASSES DATA FROM ANY ONE OF SIX INPUT PORTS, THE MEMORY BANKS, OR THE CHASSIS CONSOLE SWITCHES, ON TO THE CPU CARD.

THE SCELBI #1104 FRONT PANEL CARD ALLOWS MONITORING OF THE COMPUTER'S OPERATION. IT CAN LATCH INFORMATION BEING PASSED FROM MEMORY TO THE CPU AND MONITOR KEY LOGIC SIGNALS FROM THE CPU CARD. THE INFORMATION IS THEN DISPLAYED ON LIGHT EMITTING DIODE INDICATORS FOR THE CONVENIENCE OF THE OPERATOR. THE CARD ALSO DISPLAYS POWER STATUS TO THE COMPUTER. FOR UNATTENDED OPERATION, OR APPLICATIONS WHERE VISUAL MONITORING OF THE SYSTEM IS NOT REQUIRED, THE FRONT PANEL CARD MAY BE REMOVED FROM THE SYSTEM.

A BLOCK DIAGRAM OF THE BASIC SCELBI-8B CARD SYSTEM AND GENERAL SIGNAL FLOW IS PRESENT ON THE NEXT PAGE. MORE DETAILED DESCRIPTIONS OF EACH CARD'S OPERATION IS PRESENTED FOLLOWING THE SYSTEM BLOCK DIAGRAM.

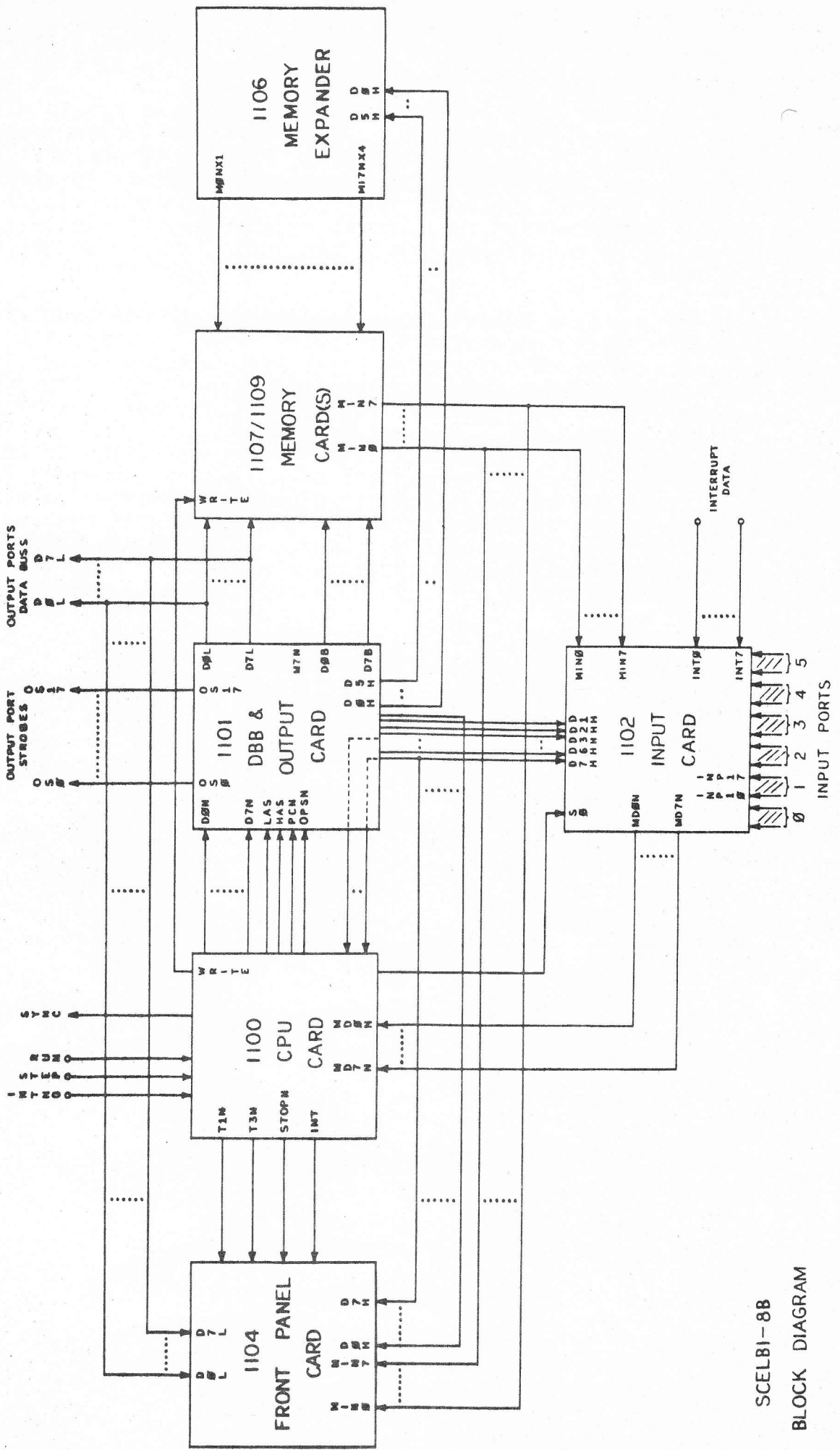

SCSELBI-8B
BLOCK DIAGRAM

THE SCLEBI #1100 CPU CARD

THE SCLEBI #1100 CPU CARD IS THE PRIMARY MODULE IN A SCLEBI-8B MINI-COMPUTER. THE CARD CONTAINS A "CPU-ON-A-CHIP" (8008), A NETWORK OF CONTROL AND TIMING LOGIC, AND A MASTER CLOCK SYSTEM. ALL COMPUTER OPERATIONS IN A SCLEBI-8B EMANATE FROM AND TERMINATE AT THIS CARD.

POWER REQUIREMENTS

+5 VOLTS: TYPICALLY 500 MA., MAXIMUM 600 MA.
-9 VOLTS: TYPICALLY 30 MA., MAXIMUM 60 MA.

OUTLINE OF CIRCUIT FUNCTIONS

A SCHEMATIC OF THE SCLEBI #1100 CPU CARD AND A PARTS LIST ARE SHOWN ON THE PAGES FOLLOWING THE DISCUSSION BELOW WHICH PROVIDES A GENERAL OUTLINE OF THE FUNCTIONS OF THE CIRCUITS ON THE CARD.

FOUR TYPE 74121 INTEGRATED CIRCUITS AND ASSOCIATED COMPONENTS FORM A TWO PHASE 500 KHZ (PLUS/MINUS 2 %) CLOCK WHICH IS PROVIDED TO THE 8008 CPU-ON-A-CHIP. IN ADDITION PHASE 2 OF THE CLOCK IS USED TO GATE A NUMBER OF DEVICES IN THE LOGIC NETWORK CONTAINED ON THE CARD.

A "SYNC" SIGNAL WHICH HAS A FREQUENCY ONE HALF THAT OF THE MASTER CLOCK IS OBTAINED FROM THE 8008 CPU-ON-A-CHIP. IT IS BUFFERED BY INVERTERS (Z10, Z12) AND MADE AVAILABLE FOR DISTRIBUTION TO THE CONTROL LOGIC ON THE CARD AS WELL AS TO EXTERNAL DEVICES WHICH MIGHT REQUIRE A HIGH SPEED "CLOCKING" SIGNAL.

CPU "STATES" FROM THE 8008 ARE BUFFERED (Z10 AND Z12) AND DECODED BY A 7442 DECODER I.C. (Z4). THE OUTPUTS OF THE DECODER ARE FED TO CONTROL LOGIC ON THE CARD AND ARE ALSO MADE AVAILABLE TO EXTERNAL DEVICES.

THE ADDRESS/DATA BUSS FROM THE 8008 IS EQUIPPED WITH A "PULL-UP" SWITCHING NETWORK CONTROLLED BY Q1 (2N2907) WHICH INCREASES THE SWITCHING SPEED OF THE BUSS (ENOUGH TO USE THE FASTER 8008-1 CPU IF DESIRED.) THE ADDRESS/DATA BUSS IS BUFFERED BY INVERTERS (Z1 AND Z10) FOR DISTRIBUTION TO OTHER CARD(S) IN A SCLEBI-8H SYSTEM. WHEN THE BUSS IS IN THE RECEIVE MODE, DATA IS ACCEPTED ONTO THE BUSS V.I.A. INTEGRATED CIRCUITS (Z2 AND Z3) WHICH ARE ENABLED BY A CONTROL SIGNAL FROM Z21.

A NETWORK OF LOGIC (PARTS OF Z12, Z13, Z14, Z22 AND Z23) ALLOWS THE CPU TO BE "INTERRUPTED" BY AN EXTERNAL SIGNAL. A STRAP OPTION PERMITS AN INTERRUPT TO BE ACCEPTED AT ANY TIME, OR ELSE ONLY WHEN THE CPU IS IN THE "STOP" STATE.

ANOTHER CONTROL SIGNAL TO THE 8008 CPU (RDYN) IS BUFFERED BY Z12. THIS ALLOWS THE CPU TO BE PLACED IN A "WAIT" STATE IF TIME IS NEEDED FOR AN EXTERNAL DEVICE TO PROVIDE DATA TO THE DATA BUSS OF THE CPU.

INTEGRATED CIRCUITS Z18, Z21A, AND PART OF Z22 ARE USED TO ALLOW CONTROL OF THE COMPUTER THROUGH THE USE OF A "STEP" MODE, OR TO PLACE THE COMPUTER IN THE AUTOMATIC "RUN" MODE.

THE REMAINING LOGIC IS USED TO PROVIDE SIGNALS TO EXTERNAL CARDS AT SPECIFIC TIMES - SUCH AS PROVIDING "STROBE" SIGNALS TO ADDRESS LATCHES AND I/O MULTIPLEXERS (SUCH AS THOSE ON THE SCFLBI TYPE #1101 DBR & OUTPUT CARD,) CONTROLLING THE READ/WRITE STATUS OF MEMORY (Z19 AND PART OF Z23,) AND PROVIDING CONTROL SIGNALS FOR OPERATION WHEN IN THE "INTERRUPT" MODE.

WHILE THE SCFLBI #1100 CPU CARD IS SPECIFICALLY TAILORED FOR USE IN THE SCFLBI-8B MINICOMPUTER, IT SHOULD BE APPARENT THAT IT IS CERTAINLY NOT LIMITED TO THAT APPLICATION. THE CARD HAS BEEN DESIGNED SO THAT IT CAN READILY BECOME AN INTEGRAL PART OF CUSTOM MADE COMPUTER/CONTROL SYSTEMS OF WIDELY VARYING DESIGN AND PURPOSE. THE SCFLBI #1100 CPU CARD CAN BE AN ECONOMICAL SOLUTION FOR CUSTOM MADE "ONE OF A KIND" SYSTEMS, AND IS ALSO CAPABLE OF SERVING IN LOW COST HIGH VOLUME OEM APPLICATIONS.

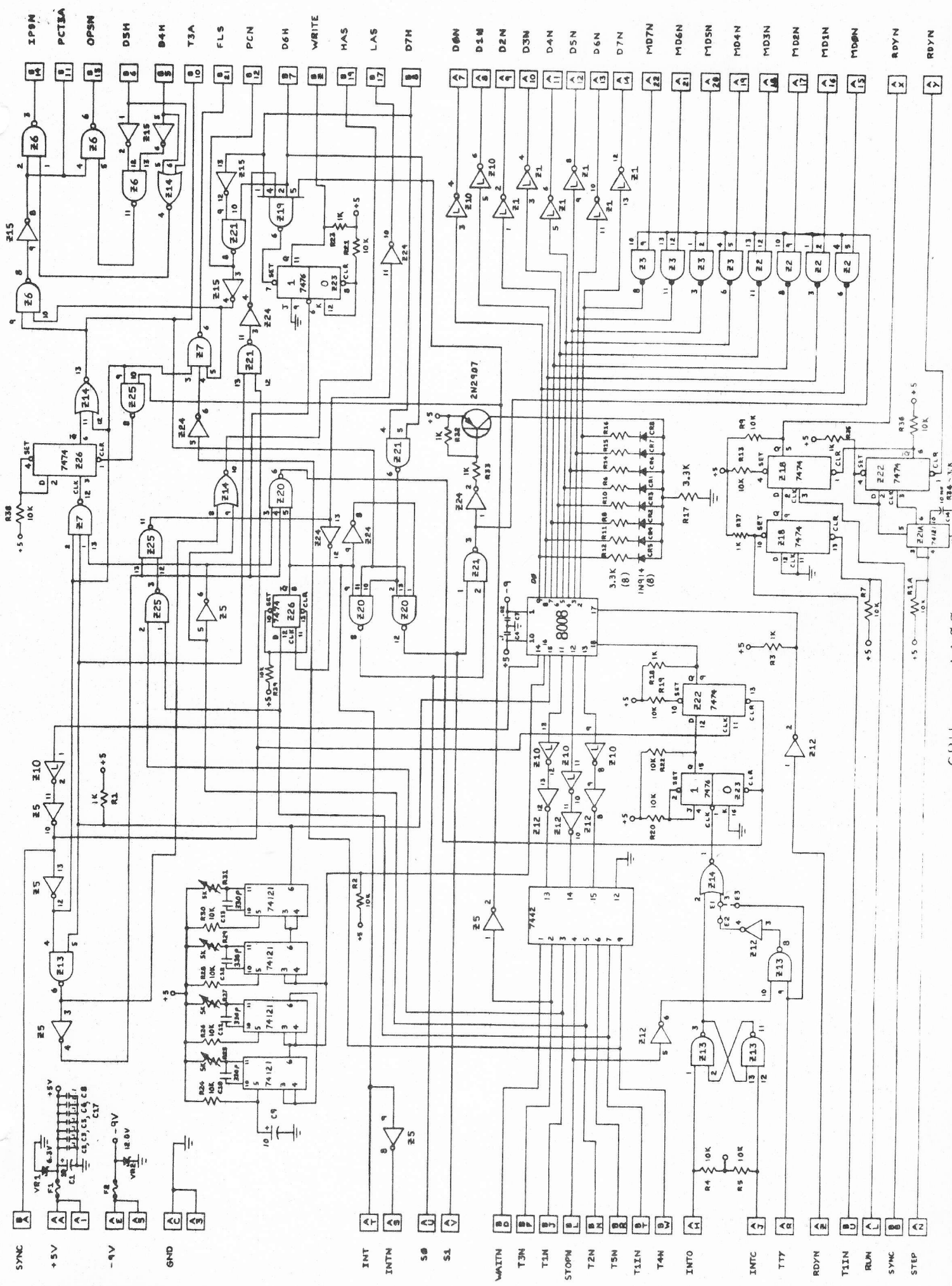

SCFLBI COMPUTER CONSULTING, INC.

1100- CPU CARD PARTS LIST

QTY	DESCRIPTION	LOCATION(S)
4	7400 INTEGRATED CIRCUIT	Z6, Z13, Z21, Z25
1	7402 INTEGRATED CIRCUIT	Z14
2	7403 INTEGRATED CIRCUIT	Z2, Z3
4	7404 INTEGRATED CIRCUIT	Z5, Z12, Z15, Z24
2	74L04 INTEGRATED CIRCUIT	Z1, Z10
2	7410 INTEGRATED CIRCUIT	Z7, Z20
1	7420 INTEGRATED CIRCUIT	Z19
1	7442 INTEGRATED CIRCUIT	Z4
3	7474 INTEGRATED CIRCUIT	Z18, Z22, Z26
1	7476 INTEGRATED CIRCUIT	Z23
5	74121 INTEGRATED CIRCUIT	Z8, Z9, Z16, Z17, Z21A
1	8008 CPU I.C.	Z11
8	1K 1/4 W RESISTOR	R1, R3, R18, R23, R32, R33, R36 R37
9	3.3K 1/4 W RESISTOR	R6, R8, R10, R11, R12, R14, R15 R16, R17
18	10K 1/4 W RESISTOR	R1A, R2, R4, R5, R7, R9, R13, R19 R20, R21, R22, R24, R26, R28 R30, R34, R35, R38, R39
1	33K 1/4 W RESISTOR	R34
4	5K TRIMPOTS	R25, R27, R29, R31
9	1N914 DIODES	CR1 - CR9
1	2N2907 TRANSISTOR	Q1
3	10 UFD FLECTROLYTIC CAP.	C1, C9, C14
7	.1 UF DISK CAPS	C2, C3, C4, C5, C6, C8, C17
1	.02 UF DISK CAP	C7
4	330 PF CAPACITORS	C10 - C13
1	6.3 VOLT ZENER DIODE	VR1

1	12.0 VOLT ZENFR DIODE	VR2
1	3/4 AMP 8AG FUSE	F1
1	1/8 AMP 8AG FUSE	F2
4	P.C. MOUNT FUSE CLIPS	
18	MOLEX PINS	
1	1100- PRINTED CKT CARD	

THE SCELBI #1101 DBB & OUTPUT CARD

THE SCELBI #1101 DBB AND OUTPUT CARD CONTAINS MEMORY ADDRESS AND STATE CONTROL LATCHES AND LOGIC FOR SELECTING BANKS OF MEMORY WORDS. IN ADDITION THE CARD CONTAINS MULTIPLEXING LOGIC THAT PROVIDES SELECT STROBE SIGNALS FOR UP TO 16 OUTPUT PORTS.

POWER REQUIREMENTS

+5 VOLTS: TYPICALLY 650 MA., MAXIMUM 750 MA.

OUTLINE OF CIRCUIT FUNCTIONS

INTEGRATED CIRCUITS Z3 AND PART OF Z15 PROVIDE BUFFERING OF THE ADDRESS/DATA BUSS AND DELIVER THESE SIGNALS TO THE HIGH AND LOW ADDRESS LATCHES (Z6 & 7 AND Z8 & Z9.) IN ADDITION THE BUFFERED DATA IS FED TO Z10 AND PART OF Z16 WHICH ACT AS DATA BUSS DRIVERS TO DELIVER THE SIGNALS TO EXTERNAL DEVICES.

PART OF I.C. Z15 PASSES THE LOW AND HIGH ADDRESS STROBE SIGNALS TO THE ADDRESS LATCHES.

INFORMATION FROM THE HIGH ADDRESS LATCHES IS PICKED UP BY Z16A AND PASSED TO DECODING CIRCUITS (Z14 AND Z17) TO PROVIDE MEMORY ENABLE SIGNALS FOR PAGES 00 THROUGH 17 (OCTAL). (THESE SIGNALS ARE NOT NORMALLY USED IN A STANDARD SCELBI-8B.)

INFORMATION FROM THE HIGH ADDRESS LATCHES IS ALSO PASSED THROUGH A NETWORK (Z1, Z2, Z4, Z5, Z11, Z12 AND Z13 PLUS PART OF Z16) THAT PROVIDES AN OUTPUT PORT SELECT STROBE WHEN AN OUTPUT INSTRUCTION IS BEING EXECUTED AND THE APPROPRIATE "OPSN" SIGNAL IS RECEIVED ON PIN 'BU' OF THE CARD AND PASSED THROUGH THE "OPSN" BUFFER (PART OF Z15).

THE LINES D5H THROUGH D0H ARE PASSED TO THE MEMORY EXPANDER CARD IN A SCELBI-8B SYSTEM FOR USE IN SELECTING MEMORY "PAGES."

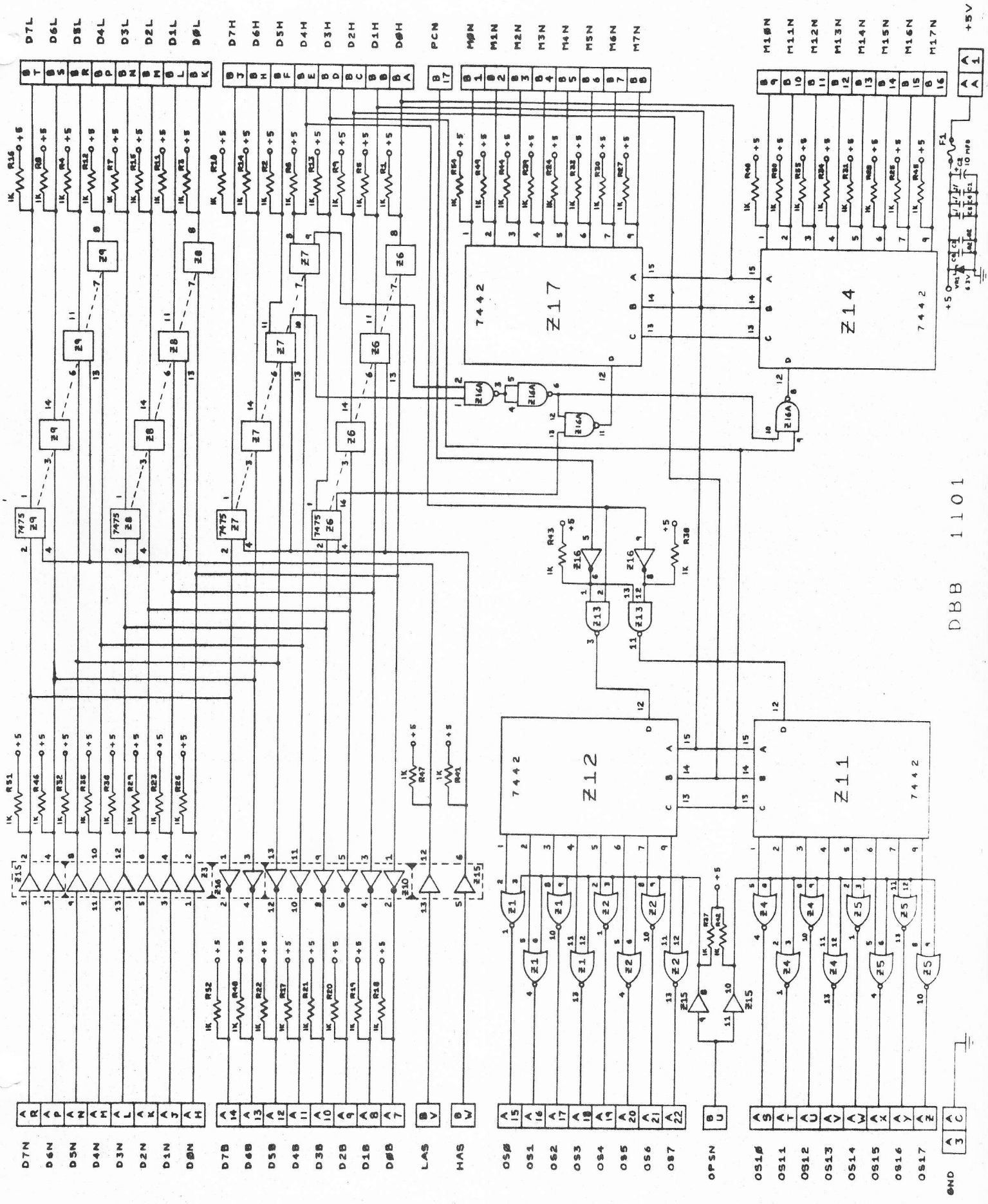

DBB 1101

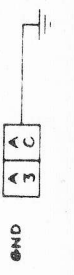
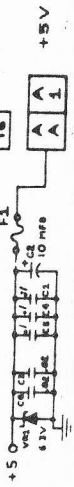

SCELBI COMPUTER CONSULTING, INC.

1101- DBB & OUTPUT CARD PARTS LIST

QTY	DESCRIPTION	LOCATION(S)
2	7400 INTEGRATED CIRCUIT	Z13, Z16A
4	7402 INTEGRATED CIRCUIT	Z1, Z2, Z4, Z5
2	7416 INTEGRATED CIRCUIT	Z10, Z16
2	7417 INTEGRATED CIRCUIT	Z3, Z15
4	7442 INTEGRATED CIRCUIT	Z11, Z12, Z14, Z17
4	7475 INTEGRATED CIRCUIT	Z6 - Z9
54	1K 1/4 W RESISTOR	R1 - R52, R54, R55
1	10 UFD ELECTROLYTIC CAP	C2
3	.1 UFD DISK CAP	C1, C4, C5
2	.02 UFD DISK CAP	C3, C6
1	6.3 VOLT ZENER DIODE	VR1
1	1.0 AMP 8AG FUSE	F1
2	P.C. MOUNT FUSE CLIPS	
1	1101- PRINTED CKT CARD	

THE SCELBI #1102 INPUT CARD

THE SCELBI #1102 INPUT CARD CONTAINS MULTIPLEXING LOGIC WHICH SEL-CTS THE INPUT TO THE CENTRAL PROCESSOR CARD (SCELBI #1100.) THE CARD ALLOWS INPUT TO THE CPU IN A SCELBI-8B MINI-COMPUTER TO ARRIVE FROM THE MEMORY BANK(S), THE CHASSIS CONSOLE SWITCHES (WHICH ARE USED TO ALLOW CONTROL OF THE COMPUTER BY AN OPERATOR) OR ANY ONE OF SIX DIFFERENT IN-PUT PORTS.

POWER REQUIREMENTS

+5 VOLTS: TYPICALLY 250 MA., MAXIMUM 300 MA.

OUTLINE OF CIRCUIT FUNCTIONS

INTEGRATED CIRCUITS Z5, Z6 AND Z11 TAKE CONTROL SIGNALS RECEIVED FROM THE SCELBI #1100 (CPU CARD) AND #1101 (DBB & OUTPUT CARD) IN A SCELBI-8H MINI-COMPUTER AND PASS THEM ONTO MULTIPLEXING INTEGRATED CIR-CUITS (Z1 - Z4 AND Z7 - Z10). THE MULTIPLEXING CIRCUITS SELECT ONE INPUT LINE (OUT OF EIGHT) AND PASSES THE SELECTED SIGNAL ON TO THE CPU CARD IN A SCELBI-8H SYSTEM. THE MULTIPLEXING ARRANGEMENTS ALLOWS ANY ONE OF SIX INPUT PORTS (PORTS 0 THROUGH 5) TO BE SELECTED, OR FOR DATA TO BE RECEIVED FROM THE MEMORY BANK(S), OR FROM AN EXTERNAL SOURCE WHEN THE COMPUTER IS IN THE INTERRUPT MODE (SUCH AS THE CHASSIS CONSOLE SWITCHES ON A SCELBI-8B MINI-COMPUTER.) IT SHOULD BE NOTED, THAT WHILE THE "INT" (INTERRUPT MODE) DATA LINES ARE USED TO ACCEPT DATA FROM THE CHASSIS SWITCHES IN A STANDARD SCELBI-8B, THESE LINES COULD BE USED TO ACCEPT DATA FROM OTHER ELECTRONIC DEVICES FOR ACHIEVING HIGHLY SOPHISTI-CATED AUTOMATIC OPERATION IN SPECIAL SYSTEMS (SUCH AS MACHINE CONTROL-ERS) BY HAVING EXTERNAL ELECTRONICS DELIVER INSTRUCTION CODES THROUGH THESE LINE WHEN THE COMPUTER WAS IN THE "INTERRUPT" MODE.

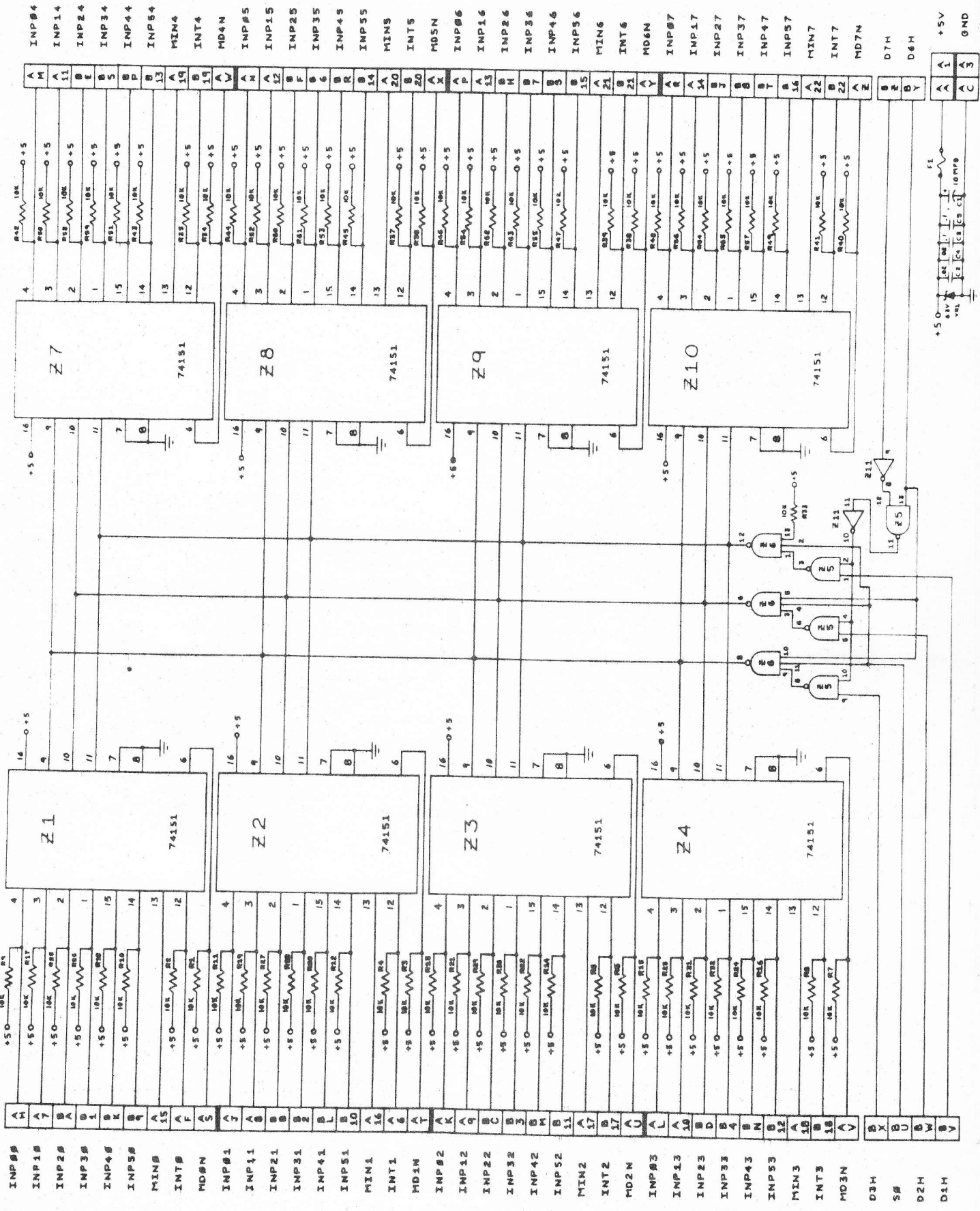

SCELBI COMPUTER CONSULTING, INC.

1102- INPUT CARD PARTS LIST

QTY	DESCRIPTION	LOCATION(S)
1	7400 INTEGRATED CIRCUIT	Z5
1	7404 INTEGRATED CIRCUIT	Z11
1	7410 INTEGRATED CIRCUIT	Z6
8	74151 INTEGRATED CIRCUIT	Z1 - Z4, Z7 - Z10
65	10K 1/4 W RESISTORS	R1 - R65
1	10 UFD ELECTROLYTIC CAP	C1
2	.1 UFD DISK CAPACITOR	C3, C5
2	.02 UFD DISK CAPACITOR	C2, C4
1	6.3 VOLT ZENER DIODE	VR1
1	3/8 AMP 8AG FUSE	F1
2	P.C. MOUNT FUSE CLIPS	
1	1102- PRINTED CIRCUIT CARD	

THE SCELBI #1104 FRONT PANEL CARD

THE SCELBI #1104 FRONT PANEL CARD HAS BEEN SPECIALLY DESIGNED TO ALLOW A SCELBI-8B USER TO MONITOR THE OPERATION OF A SCELBI-8B MINI-COMPUTER. THE CARD CONTAINS AN ARRAY OF LONG LASTING SOLID STATE LIGHT EMITTING DIODES WHICH ALLOW THE OPERATOR TO DISPLAY THE CONTENTS OF MEMORY LOCATIONS, THE CONTENTS OF INTERNAL CPU REGISTERS, MAJOR CYCLE STATES OF THE COMPUTER, AND THE GENERAL STATUS OF THE SYSTEM INCLUDING THE PRESENCE OF POWER SUPPLY VOLTAGES.

POWER REQUIREMENTS

+5 VOLTS: TYPICALLY 200 MA., MAXIMUM 250 MA.

-9 VOLTS: - - - - - MAXIMUM 10 MA.

OUTLINE OF CIRCUIT FUNCTIONS

INTEGRATED CIRCUITS Z1 AND Z3 BUFFER DATA OBTAINED FROM THE DATA OUT LINES OF THE MEMORY ELEMENTS AND PASS THEM TO LATCHES (Z2 AND Z4) THAT DRIVE THE "MEMORY CONTENTS" DISPLAY LAMPS.

BUFFERS (Z5, PARTS OF Z6 AND Z7) MONITOR THE MEMORY ADDRESS SIGNALS (OBTAINED FROM THE SCELBI #1101 DBB & OUTPUT CARD) AND DRIVE THE MEMORY ADDRESS DISPLAY LAMPS. THE TWO HIGH ORDER BITS OF THE MEMORY ADDRESS SIGNALS ACTUALLY REPRESENT CYCLE CONDITIONS OF THE 8008 CPU (ON THE SCELBI #1100 CPU CARD) AND THESE ARE ALSO DISPLAYED (LAMPS DS3 AND DS4.)

OTHER LAMPS MONITOR THE +5 VOLT AND -9 VOLT SUPPLIES, AND SEVERAL OF THE CPU "STATE" LINES ARE MONITORED TO DISPLAY THE GENERAL CONDITION OF THE COMPUTER - SUCH AS WHETHER THE MACHINE IS IN THE "RUN," "STOP," OR "INTERUPT" MODE (DS1, DS2 AND DS5.)

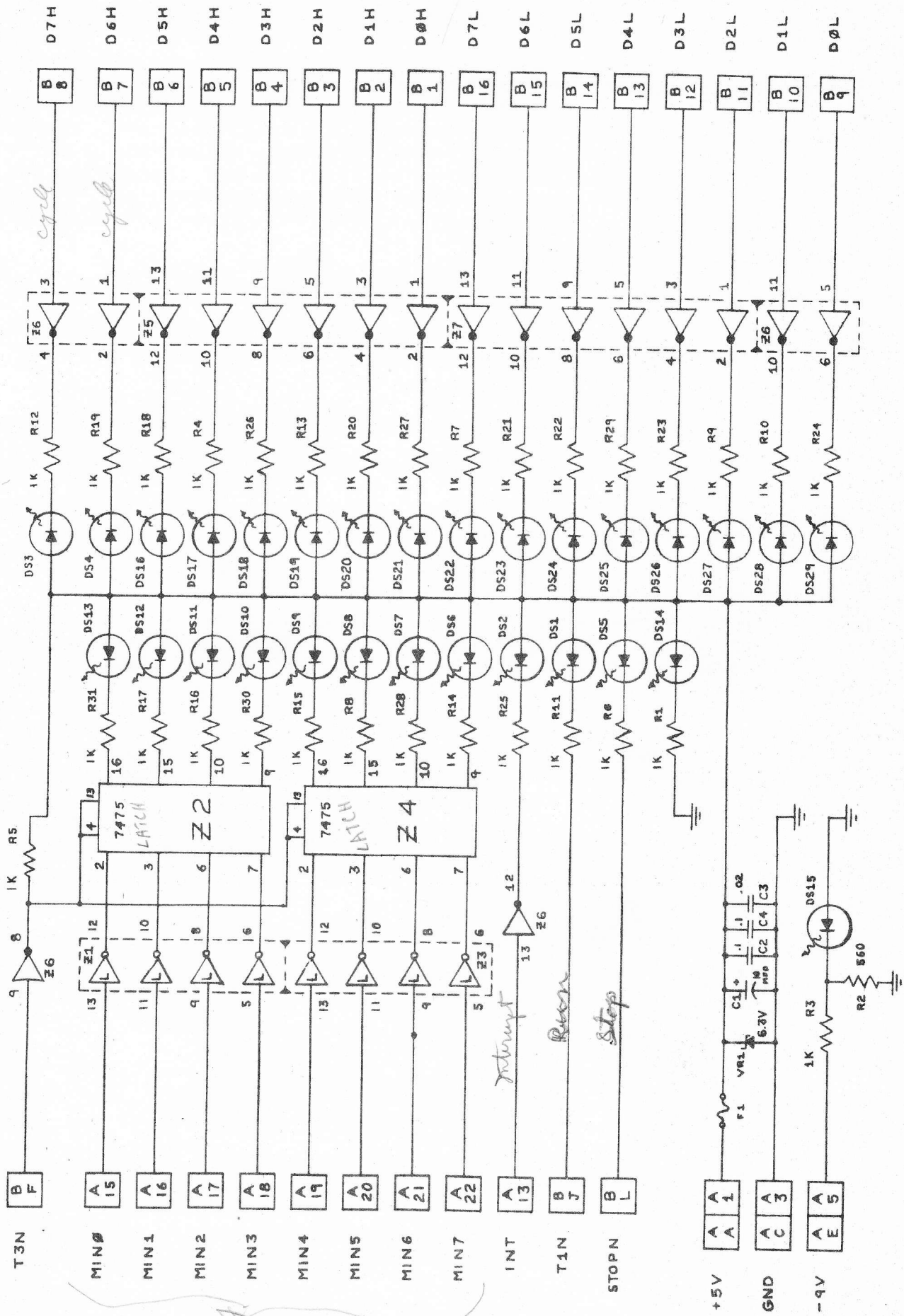

cycl

cycl

High

LOW

FRONT PANEL DISPLAY

memory

Interrupt

Reset

Stop

SCELBI COMPUTER CONSULTING, INC.

1104- FRONT PANEL CARD PARTS LIST

QTY	DESCRIPTION	LOCATION(S)
2	74L04 INTEGRATED CIRCUIT	Z1, Z3
3	7416 INTEGRATED CIRCUIT	Z5 - Z7
2	7475 INTEGRATED CIRCUIT	Z2, Z4
1	560 OHM 1/4 W RESISTOR	R2
30	1K 1/4 W RESISTOR	R1, R3 - R31
29	MV10B L.E.D.	DS1 - DS29
1	6.3 VOLT ZENER DIODE	VR1
1	10 UFD ELECTROLYTIC CAP	C1
2	.1 UFD DISK CAP	C2, C4
1	.02 UFD DISK CAP	C3
1	3/8 AMP 8AG FUSE	F1
2	P.C. MOUNT FUSE CLIPS	
1	1104- PRINTED CIRCUIT CARD	

THE SCLEBI #1106 MEMORY EXPANSION CARD

THE SCLEBI #1106 MEMORY EXPANSION CARD CONTAINS MEMORY ADDRESS LOGIC WHICH ENABLES THE COMPUTER TO SELECT THE DESIRED "PAGE" OF MEMORY IN A SYSTEM THAT MAY CONTAIN MANY "PAGES" OR "BANKS" OF MEMORY ELEMENTS.

POWER REQUIREMENTS

+5 VOLTS: TYPICALLY 200 MA., MAXIMUM 250 MA.

OUTLINE OF CIRCUIT FUNCTIONS

INTEGRATED CIRCUITS Z8 AND Z9 ACCEPTS SIGNALS FROM THE HIGH ADDRESS LATCHES PROVIDED BY THE #1101 DBB & OUTPUT CARD. THESE SIGNALS ARE THEN DECODED BY INTEGRATED CIRCUITS Z1 -Z7 AND Z10 TO PROVIDE ONE MEMORY PAGE SELECT SIGNAL OUT OF A POSSIBLE SIXTY FOUR. THE PAGE SELECT SIGNAL FOR THE DESIRED BANK OF MEMORY ELEMENTS IS "TRUE" WHEN THE SIGNAL OUTPUTTED FROM THE CARD IS IN THE LOGIC "LOW" (0) CONDITION. THE OUTPUTS FROM THE CARD ARE FED TO THE MEMORY CARD SLOTS IN A SCLEBI-8B SYSTEM.

SCELBI COMPUTER CONSULTING, INC.

1106- MEMORY EXPANSION CARD PARTS LIST

QTY	DESCRIPTION	LOCATION(S)
1	7417 INTEGRATED CIRCUIT	Z8
9	7442 INTEGRATED CIRCUIT	Z1 - Z7, Z9 & Z10
67	10K 1/4 W RESISTOR	R1 - R67
1	10 UFD ELECTROLYTIC CAP	C1
3	.1 UF DISK CAP	C2 - C4
1	6.3 VOLT ZENER DIODE	VR1
1	1.5 AMP 8AG FUSE	F1
2	P.C. MOUNT FUSE CLIPS	
1	1106- PRINTED CKT CARD	

THE SCELBI #1107 RAM MEMORY CARD

THE SCELBI #1107 RAM MEMORY CARD MAY BE POPULATED WITH TYPE 2102 (STATIC RAM) MEMORY ELEMENTS IN GROUPS OF 1,024 WORDS TO A MAXIMUM OF 4,096 WORDS PER CARD. THE CARD ALSO CONTAINS MEMORY BANK SELECTION LOGIC. THESE CARDS SERVE AS THE READ AND WRITE MEMORY BANK(S) FOR A SCELBI-8B SYSTEM. THE STANDARD SCELBI-8B CHASSIS HAS P.C. CARD SOCKETS TO ACCEPT UP TO FOUR OF THESE CARDS ALLOWING FOR UP TO 16,384 WORDS OF MEMORY TO BE USED BY THE COMPUTER.

POWER REQUIREMENTS

±5 VOLTS: TYPICALLY 600 MA., MAXIMUM 1.0 AMP

OUTLINE OF CIRCUIT FUNCTIONS

THE CARD MAY CONTAIN UP TO 32 TYPE 2102 STATIC RAM MEMORY INTEGRATED CIRCUITS. EACH I.C. SERVES TO HOLD 1 BIT OF INFORMATION AT EACH ADDRESS LOCATION IN A BLOCK OF 1,024 ADDRESSES. THEREFORE, EIGHT OF THESE DEVICES IN PARALLEL PROVIDE 1,024 FULL EIGHT BIT WORDS OF MEMORY FOR A SCELBI -8B MINICOMPUTER. THESE I.C.S MAY BE ADDED TO THE CARD IN GROUPS OF EIGHT TO PROVIDE THE CARD WITH 1,024, 2,048, 3,072 OR 4,096 WORDS OF RAM MEMORY.

INTEGRATED CIRCUITS Z9, Z10, Z19, Z20 AND Z37 SERVE TO DECODE THE "PAGE" ADDRESS INFORMATION RECEIVED FROM THE SCELBI #1106 MEMORY EXPANSION CARD AND SET THE HIGH ORDER ADDRESS BITS OF A SELECTED ROW OF 2102 I.C.S TO SELECT A BLOCK OF 256 WORDS (PAGE) OUT OF THE POSSIBLE 1,024 WORDS THAT CONTAINED IN A GROUP. IN ADDITION, THE LOGIC SELECTS THE APPROPRIATE ROW OF MEMORY ELEMENTS OUT OF THE FOUR POSSIBLE ROWS ON A CARD. THE LOW ORDER PORTION OF THE ADDRESS IS RECEIVED DIRECTLY FROM THE LOW ORDER ADDRESS LINES PROVIDED BY THE SCELBI #1101 DBB & OUTPUT CARD, ENABLING AN INDIVIDUAL WORD OUT OF A GROUP OF 256 WORDS ON A SELECTED "PAGE" TO BE ACCESSED.

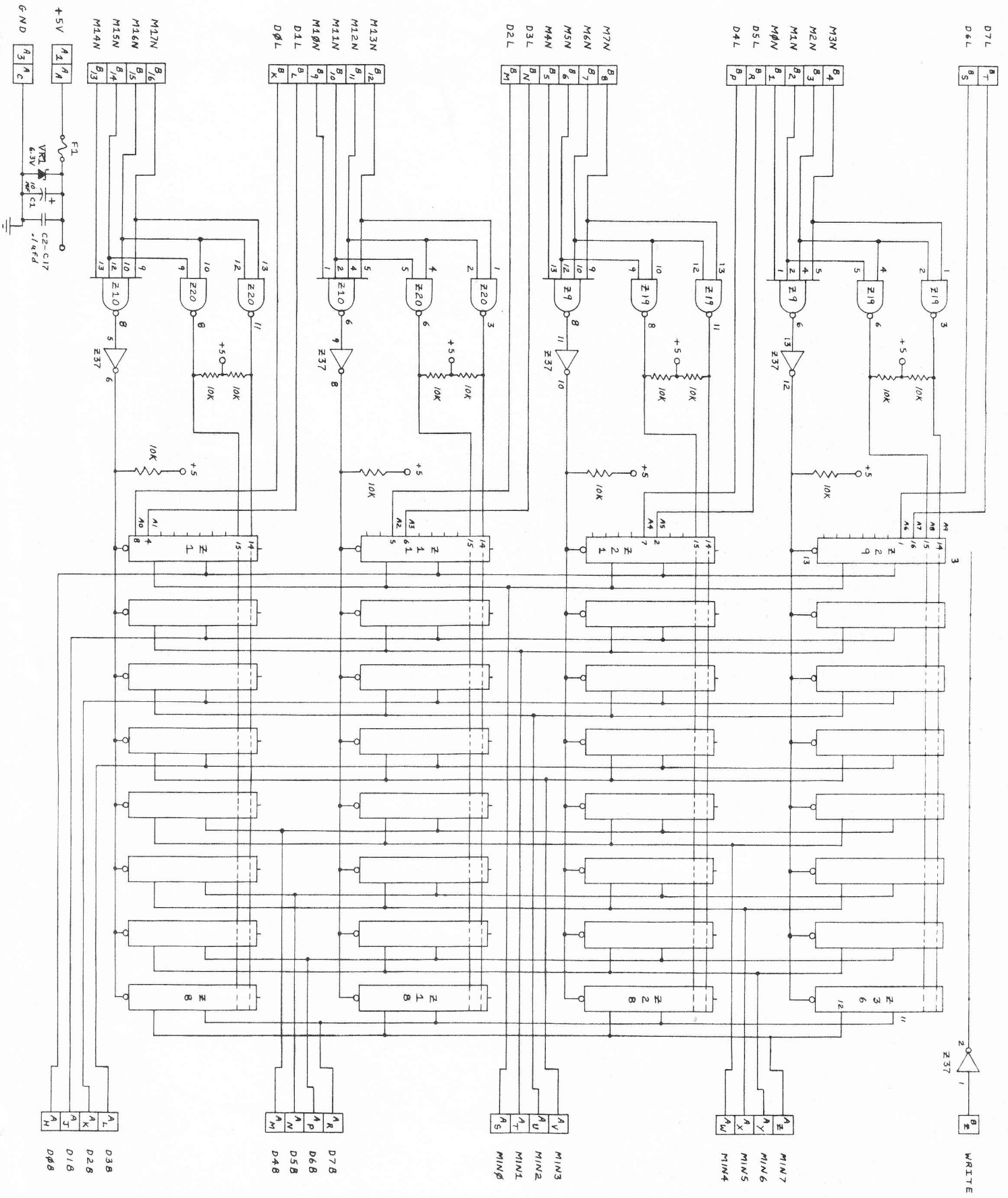

SCELBI COMPUTER CONSULTING, INC.

1107- RAM MEMORY CARD PARTS LIST

QTY	DESCRIPTION	LOCATION(S)
2	7400 INTEGRATED CIRCUIT	Z19, Z20
1	7404 INTEGRATED CIRCUIT	Z37
2	7420 INTEGRATED CIRCUIT	Z9, Z10
32	2102 1K STATIC RAM I.C.	Z1 - Z8, Z11-Z18, Z21 - Z28 Z29 - Z36
12	10K 1/4 W RESISTOR	R1 - R12
1	10 UFD ELECTROLYTIC CAP	C1
16	.1 UF DISK CAP	C2 - C17
1	6.3 VOLT ZENER DIODE	VR1
2	1.5 AMP 8AG FUSE	F1, F2
4	P.C. MOUNT FUSE CLIPS	
1	1107- PRINTED CKT CARD	

THE SCELBI #1109 ROM/PROM MEMORY CARD

THE SCELBI #1109 ROM/PROM MEMORY CARD IS AN OPTIONAL CARD. THE CARD MAY BE POPULATED WITH UP TO 16 TYPE 1602 ROMS OR 1702 PROMS. AT 256 WORDS PER ROM THIS ALLOWS UP TO 4,096 WORDS OR ROM MEMORY TO BE STORED ONE EACH CARD. THE CARD MAY BE PLUGGED INTO ANY MEMORY CARD SLOT IN A SCELBI-5B SYSTEM TO SUBSTITUTE ROM/PROM MEMORY FOR RAM MEMORY.

POWER REQUIREMENTS

+5 VOLTS: TYPICALLY 1.0 AMP., MAXIMUM 1.5 AMP.

-9 VOLTS: TYPICALLY 1.0 AMP., MAXIMUM 1.5 AMP.

OUTLINE OF CIRCUIT FUNCTIONS

THE CARD HOLDS UP TO 16 INDIVIDUAL ROM/PROM DEVICES. EACH DEVICE IS A SELF CONTAINED UNIT HOLDING 256 EIGHT BIT WORDS OF READ ONLY MEMORY. AN INDIVIDUAL DEVICE IS SELECTED BY ACTIVATION OF AN APPROPRIATE MEMORY ADDRESS PAGE SELECT LINE PROVIDED BY THE SCELBI #1106 MEMORY EXPANSION CARD. THE ADDRESS WITHIN A DEVICE IS SELECTED BY THE INFORMATION ON THE LOW ADDRESS LINES PROVIDED BY THE SCELBI #1101 DBB & OUTPUT CARD.

SCELBI COMPUTER CONSULTING, INC.

1109- ROM/PROM MEMORY CARD PARTS LIST

QTY	DESCRIPTION	LOCATION(S)
16	1602 ROM OR 1702 PROM I.C.	Z1 - Z16
16	24 PIN I.C. SOCKET	SK1 - SK16
1	10 UFD ELECTROLYTIC CAP	C1
4	.1 UF DISK CAP	C3, C5, C7, C9
4	.02 UF DISK CAP	C2, C4, C6, C8
1	6.3 VOLT ZENER DIODE	VR1
1	12 VOLT ZENER DIODE	VR2
2	1.5 AMP BAG FUSE	F1, F2
4	P.C. MOUNT FUSE CLIPS	
1	1109- PRINTED CKT CARD	